

# Studio del flusso dei $v$ solari

# Neutrinos from the Sun

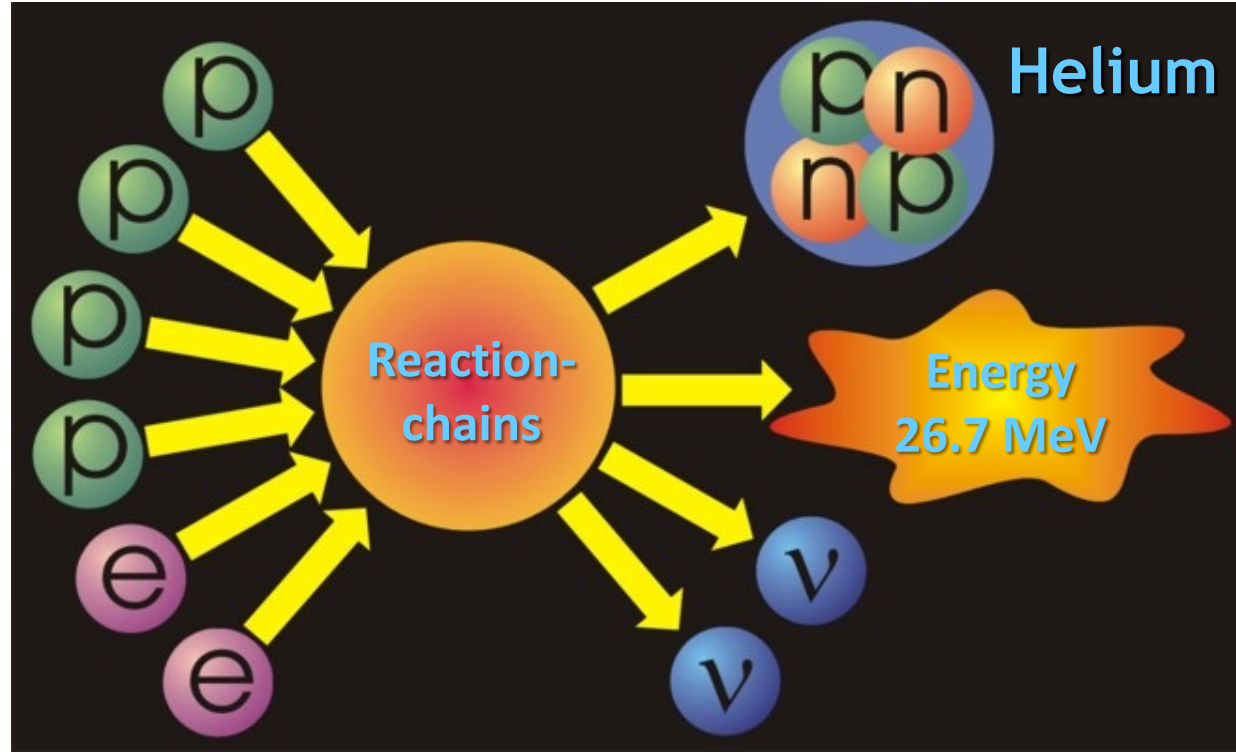
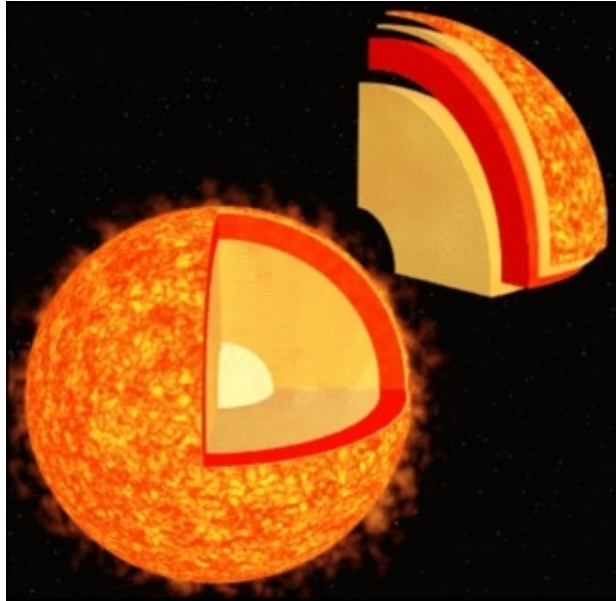

**Solar radiation: 98 % light**

**2 % neutrinos**

**At Earth 66 billion neutrinos/cm<sup>2</sup> sec**

Hans Bethe (1906–2005, Nobel prize 1967)

Thermonuclear reaction chains (1938)

# 1938 -- Thermonuclear reaction chains

Hans Bethe (Nobel prize 1967)



MARCH 1, 1939

PHYSICAL REVIEW

VOLUME 55

## Energy Production in Stars\*

H. A. BETHE

Cornell University, Ithaca, New York

(Received September 7, 1938)

It is shown that the most important source of energy in ordinary stars is the reactions of carbon and nitrogen with protons. These reactions form a cycle in which the original nucleus is reproduced, *vis.*  $C^{12}+H=N^{13}$ ,  $N^{13}=C^{13}+\epsilon^+$ ,  $C^{13}+H=N^{14}$ ,  $N^{14}+H=O^{15}$ ,  $O^{15}=N^{15}+\epsilon^+$ ,  $N^{15}+H=C^{12}+He^4$ . Thus carbon and nitrogen merely serve as catalysts for the combination of four protons (and two electrons) into an  $\alpha$ -particle (§7).

The carbon-nitrogen reactions are unique in their cyclical character (§8). For all nuclei lighter than carbon, reaction with protons will lead to the emission of an  $\alpha$ -particle so that the original nucleus is permanently destroyed. For all nuclei heavier than fluorine, only radiative capture of the protons occurs, also destroying the original nucleus. Oxygen and fluorine reactions mostly lead back to nitrogen. Besides, these heavier nuclei react much more slowly than C and N and are therefore unimportant for the energy production.

The agreement of the carbon-nitrogen reactions with observational data (§7, 9) is excellent. In order to give the correct energy evolution in the sun, the central temperature of the sun would have to be 18.5 million degrees while

integration of the Eddington equations gives 19. For the brilliant star Y Cygni the corresponding figures are 30 and 32. This good agreement holds for all bright stars of the main sequence, but, of course, not for giants.

For fainter stars, with lower central temperatures, the reaction  $H+H=D+\epsilon^+$  and the reactions following it, are believed to be mainly responsible for the energy production. (§10)

It is shown further (§5-6) that no elements heavier than  $He^4$  can be built up in ordinary stars. This is due to the fact, mentioned above, that all elements up to boron are disintegrated by proton bombardment ( $\alpha$ -emission!) rather than built up (by radiative capture). The instability of  $Be^8$  reduces the formation of heavier elements still further. The production of neutrons in stars is likewise negligible. The heavier elements found in stars must therefore have existed already when the star was formed.

Finally, the suggested mechanism of energy production is used to draw conclusions about astrophysical problems, such as the mass-luminosity relation (§10), the stability against temperature changes (§11), and stellar evolution (§12).

### §1. INTRODUCTION

THE progress of nuclear physics in the last few years makes it possible to decide rather definitely which processes can and which cannot occur in the interior of stars. Such decisions will be attempted in the present paper, the discussion being restricted primarily to main sequence stars. The results will be at variance with some current hypotheses.

The first main result is that, under present conditions, no elements heavier than helium can be built up to any appreciable extent. Therefore we must assume that the heavier elements were built up *before* the stars reached their present state of temperature and density. No attempt will be made at speculations about this previous state of stellar matter.

The energy production of stars is then due entirely to the combination of four protons and two electrons into an  $\alpha$ -particle. This simplifies the discussion of stellar evolution inasmuch as

the amount of heavy matter, and therefore the opacity, does not change with time.

The combination of four protons and two electrons can occur essentially only in two ways. The first mechanism starts with the combination of two protons to form a deuteron with positron emission, *viz.*

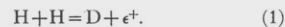

The deuteron is then transformed into  $He^4$  by further capture of protons; these captures occur very rapidly compared with process (1). The second mechanism uses carbon and nitrogen as catalysts, according to the chain reaction

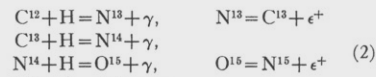

The catalyst  $C^{12}$  is reproduced in all cases except about one in 10,000, therefore the abundance of carbon and nitrogen remains practically unchanged (in comparison with the change of the number of protons). The two reactions (1) and

1938: no  $\nu$  in the nuclear reactions ...

The combination of four protons and two electrons can occur essentially only in two ways. The first mechanism starts with the combination of two protons to form a deuteron with positron emission, *viz.*

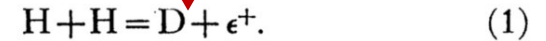

The deuteron is then transformed into  $He^4$  by further capture of protons; these captures occur very rapidly compared with process (1). The second mechanism uses carbon and nitrogen as catalysts, according to the chain reaction

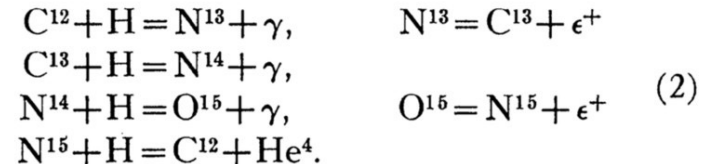

\* Awarded an A. Cressy Morrison Prize in 1938, by the New York Academy of Sciences.

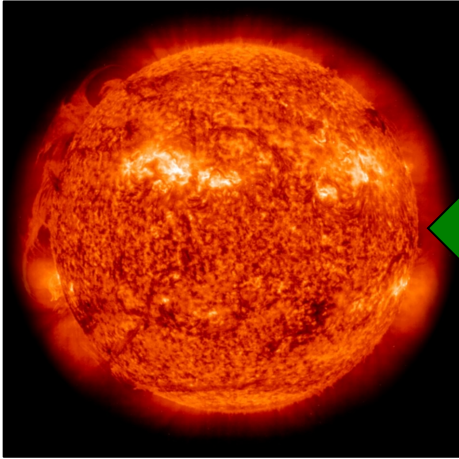

**Several light years of Pb  
needed to shield solar  $\nu$**

**Bethe & Peierls 1934:  
*... this evidently means  
that one will never be able  
to observe a neutrino.***

# First evidences of anomalies in the neutrino field arrived from **solar neutrinos** (end of '60 and '70)

The solar  $\nu$  are produced in the nuclear reactions in the solar core:

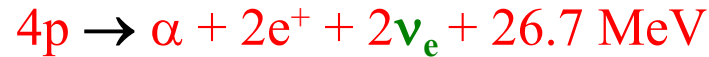

*pp chain*

*CNO cycle*

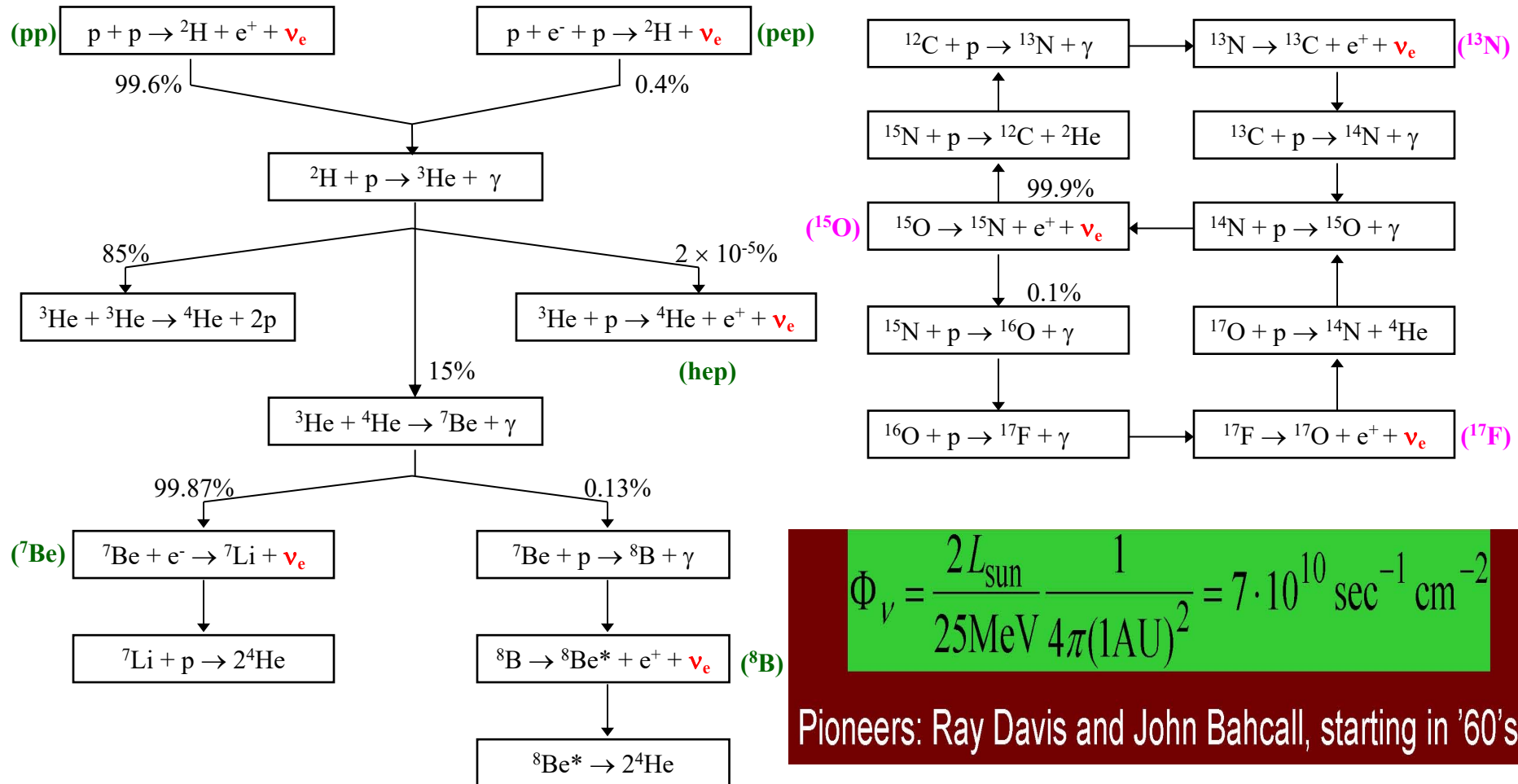

$$\Phi_\nu = \frac{2L_{\text{sun}}}{25\text{MeV}} \frac{1}{4\pi(1\text{AU})^2} = 7 \cdot 10^{10} \text{ sec}^{-1} \text{ cm}^{-2}$$

Pioneers: Ray Davis and John Bahcall, starting in '60's

# Standard Solar Model (SSM)

A **solar model** is a solution of evolution equations satisfying some contour conditions ( $M_{\oplus}$ ,  $L_{\oplus}$ ,  $R_{\oplus}$ )

- Stellar evolution models:
  - Hydrodynamic equilibrium between pressure and gravity
  - Energy transport by radiation and convection
  - Energy production by nuclear reactions
    - Can produce  $\nu$ 's here
- Many experimental and theoretical inputs:
  - Age, luminosity, opacity, abundances, radius, surface temp, core temp, core density, diffusion parameters.
- Output:
  - Temp(r), density(r)
  - **Neutrino Flux**

The sun produces  $\nu$ 's through the chain...

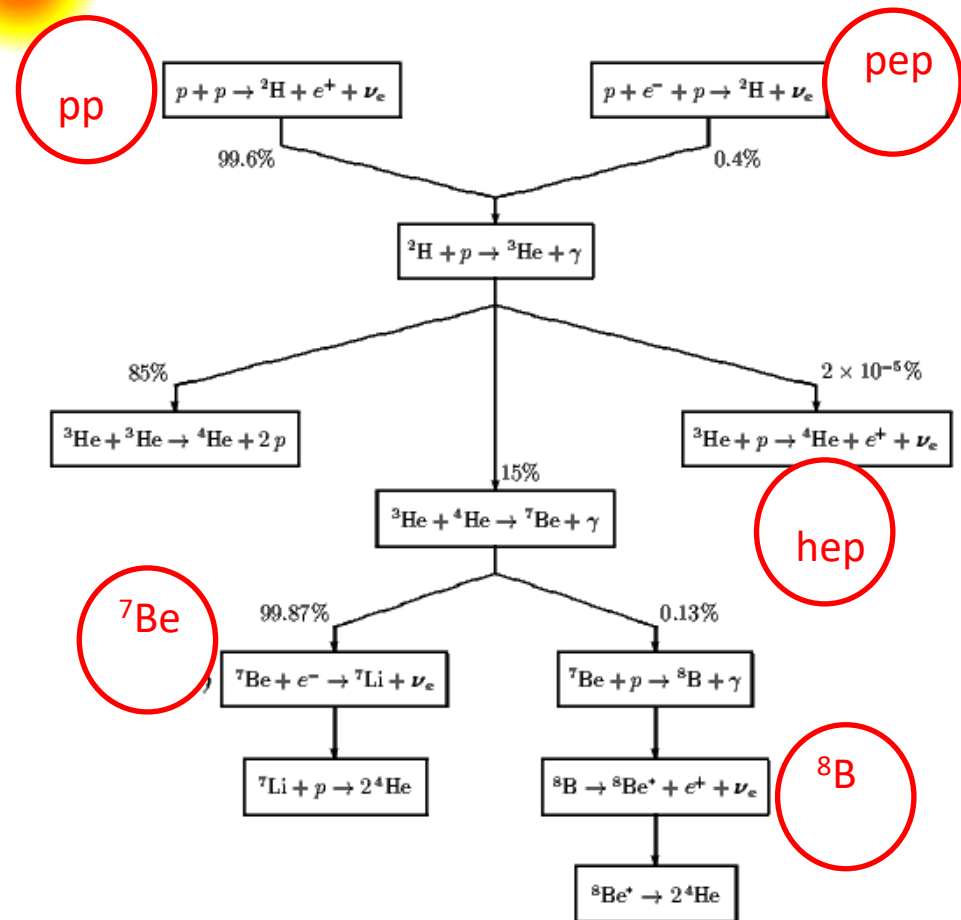

# Self-Regulated Nuclear Burning

Virial Theorem:  $\langle E_{\text{kin}} \rangle = -\frac{1}{2} \langle E_{\text{grav}} \rangle$

Small Contraction

- Heating
- Increased nuclear burning
- Increased pressure
- Expansion

Additional energy loss (“cooling”)

- Loss of pressure
- Contraction
- Heating
- Increased nuclear burning

Hydrogen burning at nearly fixed T

- Gravitational potential nearly fixed:  
 $G_{\text{N}}M/R \sim \text{constant}$
- $R \propto M$  (More massive stars bigger)

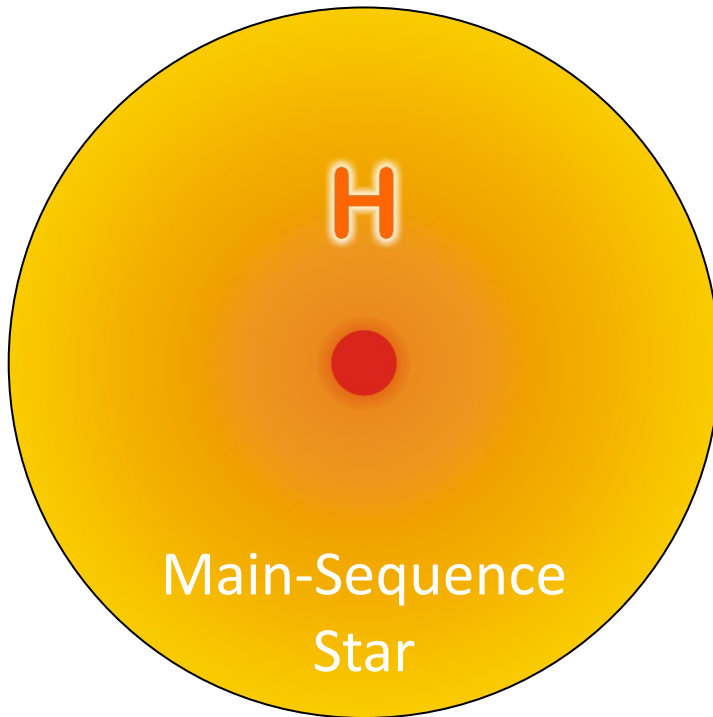

## Equations of Stellar Structure

Assume spherical symmetry and static structure (neglect kinetic energy)

Excludes: Rotation, convection, magnetic fields, supernova-dynamics, ...

Hydrostatic equilibrium

$$\frac{dP}{dr} = -\frac{G_N M_r \rho}{r^2}$$

Energy conservation

$$\frac{dL_r}{dr} = 4\pi r^2 \epsilon \rho$$

Energy transfer

$$L_r = \frac{4\pi r^2}{3\kappa\rho} \frac{d(aT^4)}{dr}$$

Literature

- Clayton: Principles of stellar evolution and nucleosynthesis (Univ. Chicago Press 1968)
- Kippenhahn & Weigert: Stellar structure and evolution (Springer 1990)

$r$  Radius from center

$P$  Pressure

$G_N$  Newton's constant

$\rho$  Mass density

$M_r$  Integrated mass up to  $r$

$L_r$  Luminosity (energy flux)

$\epsilon$  Local rate of energy generation [erg g<sup>-1</sup>s<sup>-1</sup>]

$$\epsilon = \epsilon_{\text{nuc}} + \epsilon_{\text{grav}} - \epsilon_{\nu}$$

$\kappa$  Opacity

$$\kappa^{-1} = \kappa_{\gamma}^{-1} + \kappa_{\text{c}}^{-1}$$

$\kappa_{\gamma}$  Radiative opacity

$$\kappa_{\gamma}\rho = \langle \lambda_{\gamma} \rangle_{\text{Rosseland}}^{-1}$$

$\kappa_{\text{c}}$  Electron conduction

$$dF = -\frac{G_N M(r) \rho dr dS}{r^2} \quad \longrightarrow \quad \frac{dF}{dr dS} = -\frac{G_N M(r) \rho}{r^2} \quad \longrightarrow \quad \frac{dP}{dr} = -\frac{G_N M(r) \rho}{r^2}$$

The cumulative mass increases with radius according to the **mass continuity equation**:

$$\frac{dm}{dr} = 4\pi r^2 \rho$$

Integrating the mass continuity equation from the star center ( $r=0$ ) to the radius of the star ( $r=R$ ) yields the total mass of the star.

Considering the energy leaving the spherical shell yields the energy equation:  $\frac{dL}{dr} = 4\pi r^2 \rho \epsilon$   
 Integrating the energy equation from the star center to the radius of the star yields the total luminosity of the star.

- By integrating the **Fick's first law** over the surface of some radius  $r$ , one gets the total outgoing energy flux,  $L(r)$ , which is equal to the luminosity by the energy conservation:

$$L(r) = 4\pi r^2 D \frac{\partial u}{\partial r}$$

- where  $D$  is the **photons diffusion coefficient**. In the elementary theory of diffusion coefficient in gases:  $D \approx \frac{1}{3} c \lambda = \frac{c}{3\kappa\rho}$ ; where  $\lambda$  is the photon mean free path and is the reciprocal of the **opacity**  $\kappa$ . ( $[\kappa] = \frac{1}{g/cm^2}$ ;  $[\kappa\rho] = \frac{1}{cm}$ )
- $u$  is the **energy density** related to the temperature by **Stefan-Boltzmann law** by :  $u = \frac{4}{c} \sigma T^4$

$$L(r) = \frac{4\pi r^2 c}{3\kappa\rho} \frac{\partial}{\partial r} \left( \frac{4}{c} \sigma T^4 \right) = \frac{4\pi r^2}{3\kappa\rho} \frac{\partial}{\partial r} (4\sigma T^4)$$

# Present day interior solar structure

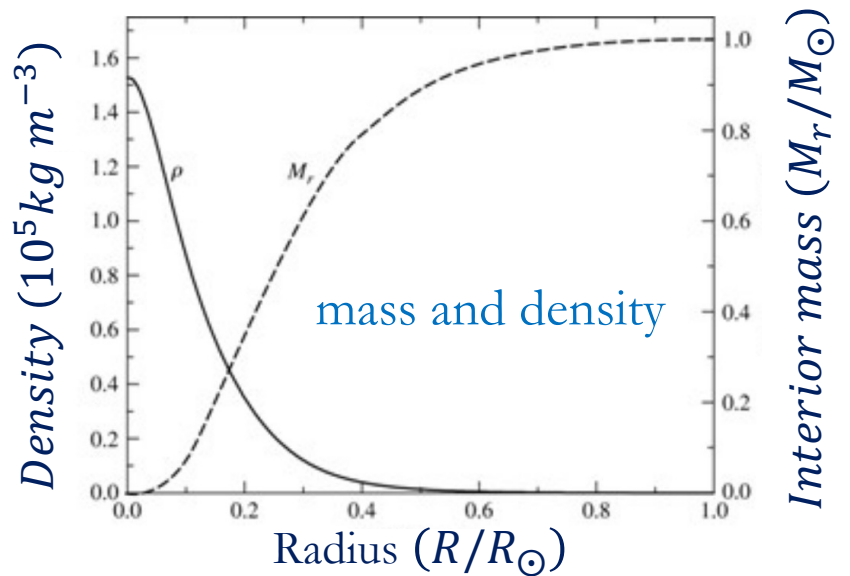
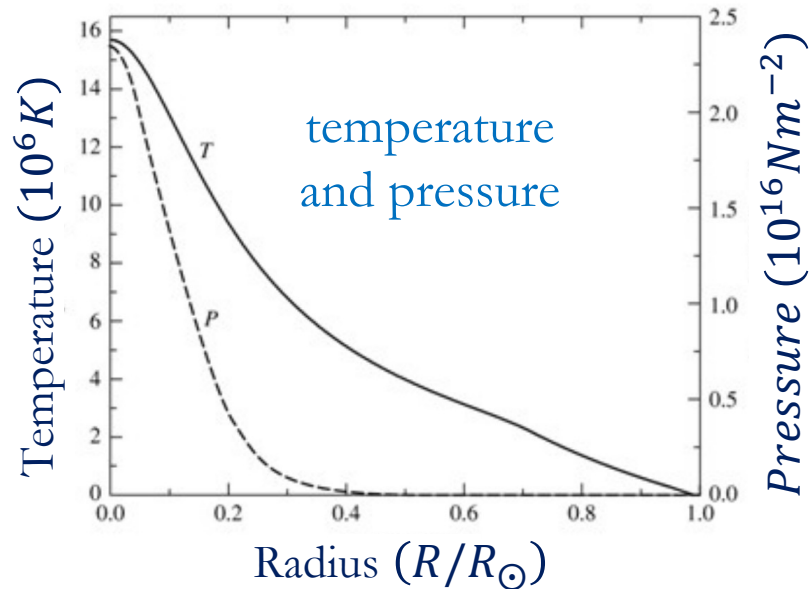
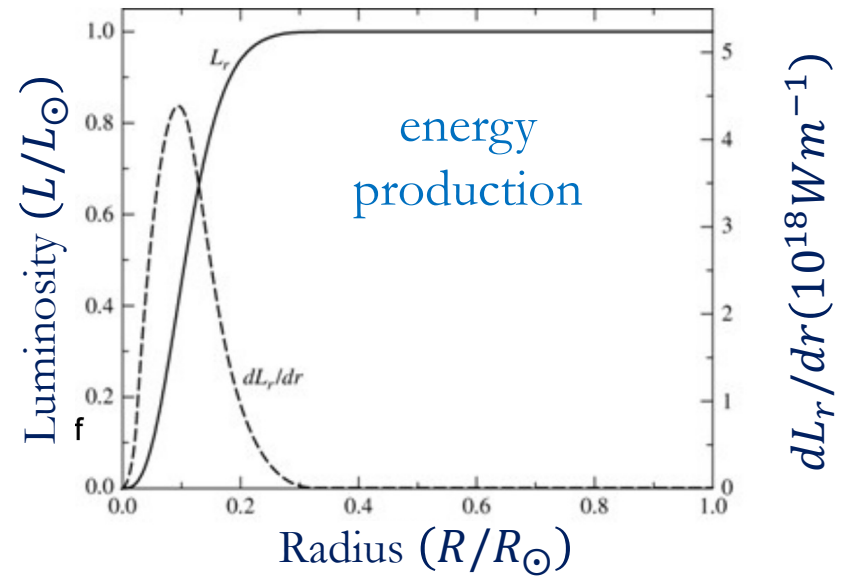
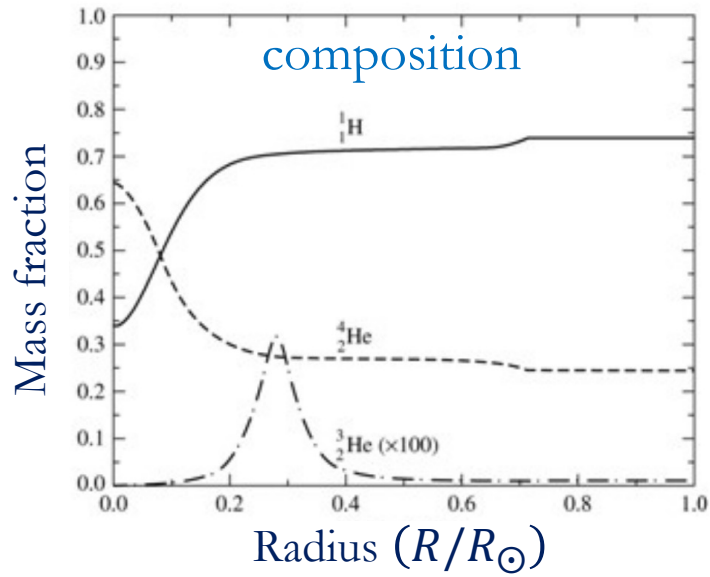

# Virial Theorem and Hydrostatic Equilibrium

Hydrostatic equilibrium

$$\frac{dP}{dr} = - \frac{G_N M_r \rho}{r^2}$$

Integrate both sides

$$\int_0^R dr 4\pi r^3 P' = - \int_0^R dr 4\pi r^3 \frac{G_N M_r \rho}{r^2}$$

L.h.s. partial integration  
with  $P = 0$  at surface  $R$

$$-3 \int_0^R dr 4\pi r^2 P = E_{\text{grav}}^{\text{tot}}$$

Monatomic gas:  $P = \frac{2}{3} U$   
( $U$  density of internal energy)

$$U^{\text{tot}} = -\frac{1}{2} E_{\text{grav}}^{\text{tot}}$$

Average energy of single  
“atoms” of the gas

$$\langle E_{\text{kin}} \rangle = -\frac{1}{2} \langle E_{\text{grav}} \rangle$$

**Virial Theorem:**

**Most important tool to study  
self-gravitating systems**

# Virial Theorem Applied to the Sun

Virial Theorem  $\langle E_{\text{kin}} \rangle = -\frac{1}{2} \langle E_{\text{grav}} \rangle$

Approximate Sun as a homogeneous sphere with

Mass  $M_{\text{sun}} = 1.99 \times 10^{33} \text{g}$

Radius  $R_{\text{sun}} = 6.96 \times 10^{10} \text{cm}$

Gravitational potential energy of a proton near center of the sphere

$$\langle E_{\text{grav}} \rangle = -\frac{3}{2} \frac{G_N M_{\text{sun}} m_p}{R_{\text{sun}}} = -3.2 \text{ keV}$$

Thermal velocity distribution

$$\langle E_{\text{kin}} \rangle = \frac{3}{2} k_B T = -\frac{1}{2} \langle E_{\text{grav}} \rangle$$

Estimated temperature

$$T = 1.1 \text{ keV}$$

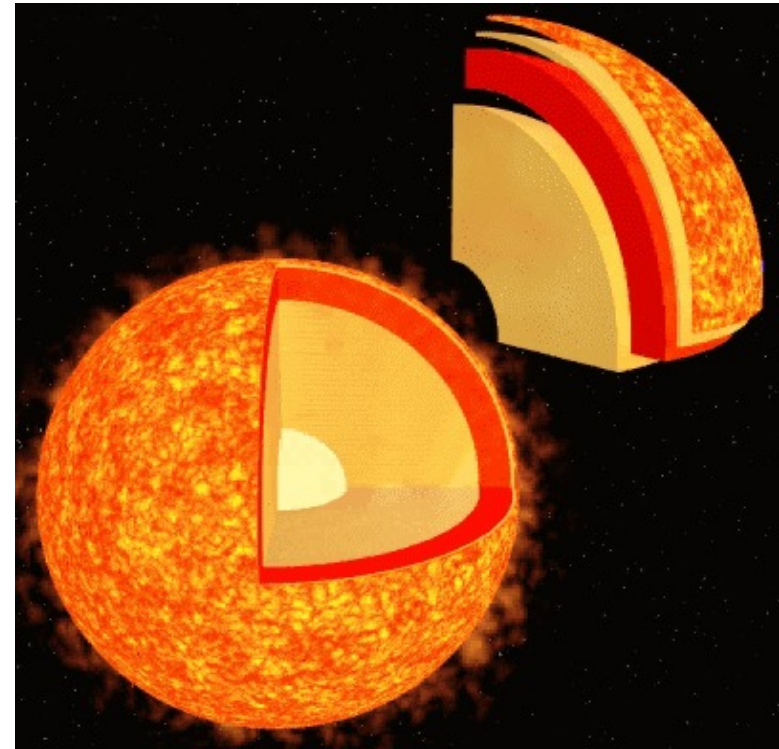

Central temperature from standard solar models:

$$T_c = 1.56 \times 10^7 \text{ K} = 1.34 \text{ keV}$$

# Thermonuclear Reactions and Gamow Peak

Coulomb repulsion prevents nuclear reactions, except for Gamow tunneling

Tunneling probability

$$p \propto E^{-1/2} e^{-2\pi\eta}$$

With Sommerfeld parameter

$$\eta = \left(\frac{m}{2E}\right)^{1/2} Z_1 Z_2 e^2$$

Parameterize cross section with astrophysical S-factor

$$S(E) = \sigma(E) E e^{2\pi\eta(E)}$$

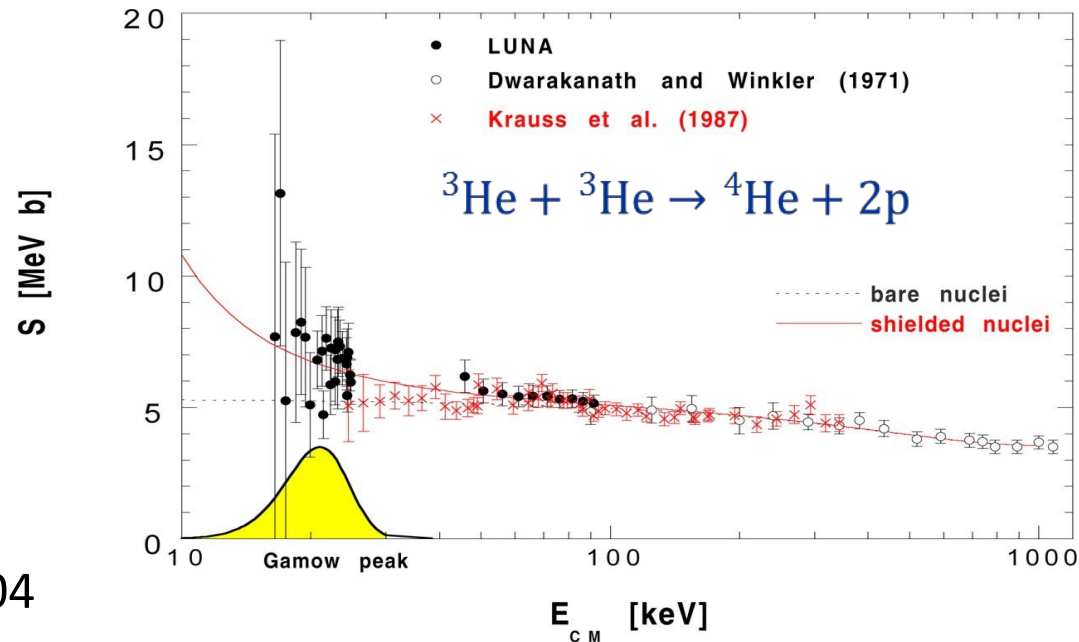
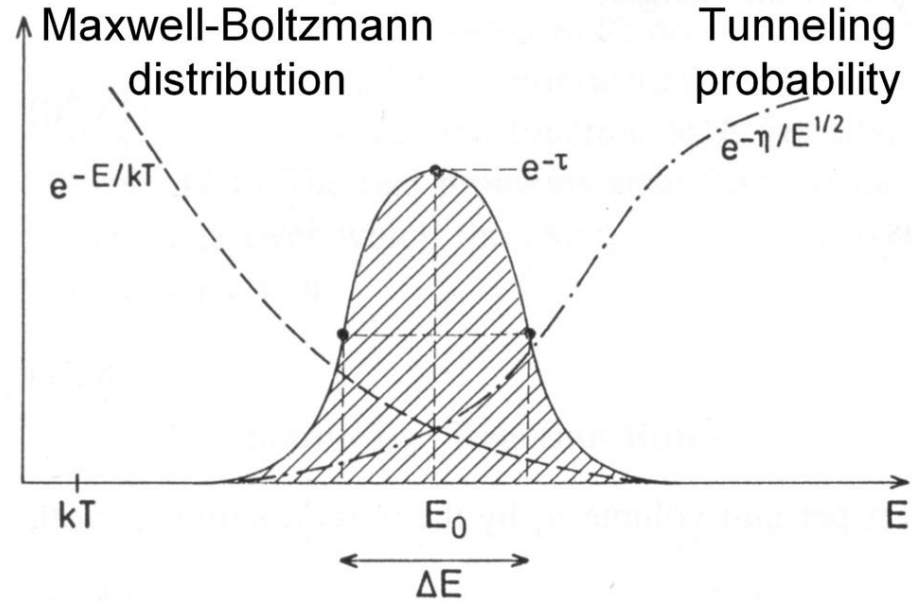

# Hydrogen Burning: Proton-Proton Chains

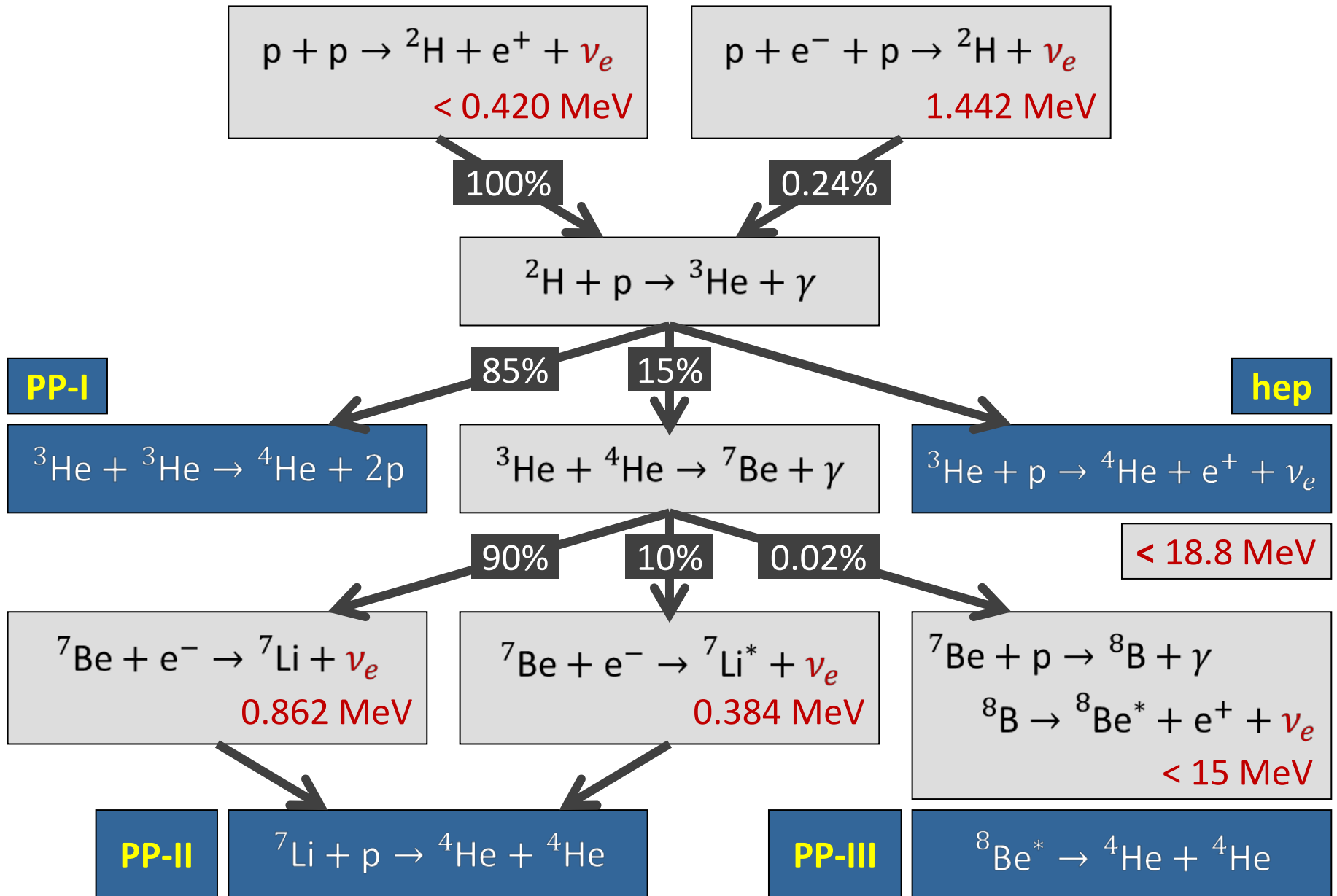



# Solar Neutrino Spectrum

- Many fusion processes in the sun lead to  $\nu$ 's
- Solar model predicts flux
  - From solar luminosity, main pp neutrino flux known to 1%
  - ${}^7\text{Be}$  and  ${}^8\text{B}$  neutrinos 10% to 20% uncertainties

Solar neutrino flux in SSM

Source	Flux ( $10^{10} \text{ cm}^{-2} \text{ s}^{-1}$ )
pp	6.0
pep	0.014
hep	$8 \times 10^{-7}$
${}^7\text{Be}$	0.47
${}^8\text{B}$	$5.8 \times 10^{-4}$
${}^{13}\text{N}$	0.06
${}^{15}\text{O}$	0.05
${}^{17}\text{F}$	$5.2 \times 10^{-4}$

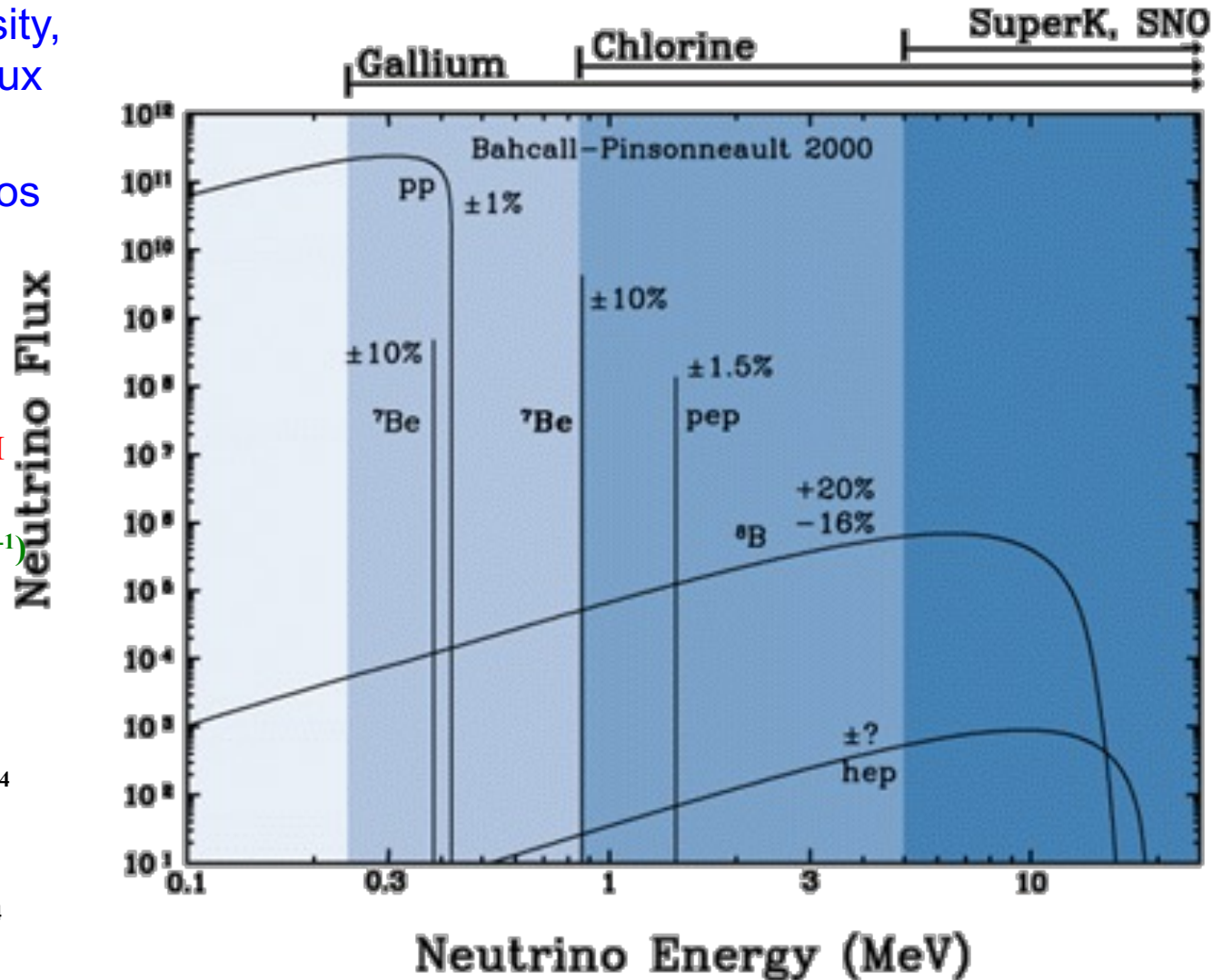

# Proposing the First Solar Neutrino Experiment

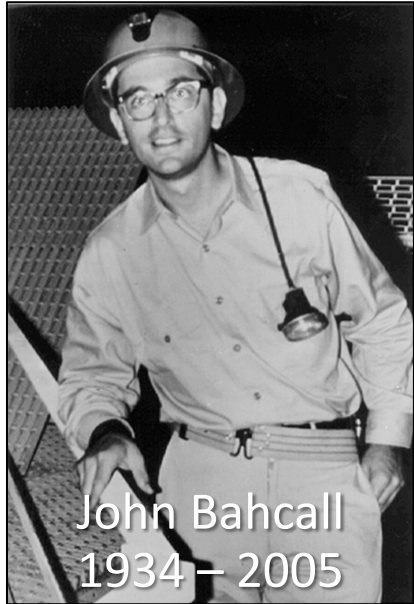

John Bahcall  
1934 – 2005

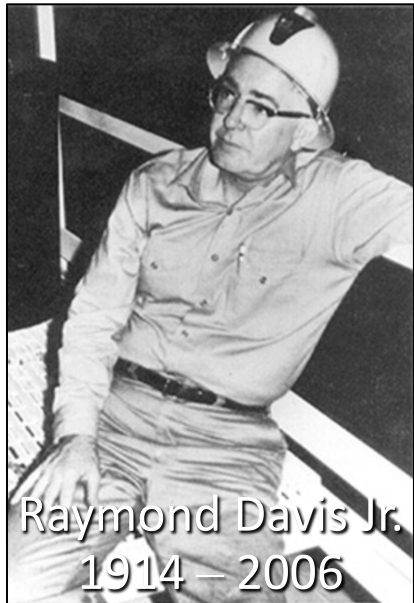

Raymond Davis Jr.  
1914 – 2006

## SOLAR NEUTRINOS. I. THEORETICAL\*

John N. Bahcall

California Institute of Technology, Pasadena, California

(Received 6 January 1964)

The principal energy source for main-sequence stars like the sun is believed to be the fusion, in the deep interior of the star, of four protons to form an alpha particle.<sup>1</sup> The fusion reactions are thought to be initiated by the sequence  ${}^1\text{H}(p, e^+\nu){}^2\text{H}(p, \gamma){}^3\text{He}$  and terminated by the following sequences: (i)  ${}^3\text{He}({}^3\text{He}, 2p){}^4\text{He}$ ; (ii)  ${}^3\text{He}(\alpha, \gamma){}^7\text{Be}(e^-\nu){}^7\text{Li}(p, \alpha){}^4\text{He}$ ; and (iii)  ${}^3\text{He}(\alpha, \gamma){}^7\text{Be}(p, \gamma){}^8\text{B}(e^+\nu){}^8\text{Be}^*(\alpha){}^4\text{He}$ . No direct evidence for the existence of nuclear reactions in the interiors of stars has yet been obtained because the mean free path for photons emitted in the center of a

star is typically less than  $10^{-10}$  of the radius of the star. Only neutrinos, with their extremely small interaction cross sections, can enable us to see into the interior of a star and thus verify directly the hypothesis of nuclear energy generation in stars.

The most promising method<sup>2</sup> for detecting solar neutrinos is based upon the endothermic reaction ( $Q = -0.81$  MeV)  ${}^{37}\text{Cl}(\nu_{\text{solar}}, e^-){}^{37}\text{Ar}$ , which was first discussed as a possible means of detecting neutrinos by Pontecorvo<sup>3</sup> and Alvarez.<sup>4</sup> In this note, we predict the number of absorptions of

300

VOLUME 12, NUMBER 11

PHYSICAL REVIEW LETTERS

16 MARCH 1964

## SOLAR NEUTRINOS. II. EXPERIMENTAL\*

Raymond Davis, Jr.

Chemistry Department, Brookhaven National Laboratory, Upton, New York

(Received 6 January 1964)

The prospect of observing solar neutrinos by means of the inverse beta process  ${}^{37}\text{Cl}(\nu, e^-){}^{37}\text{Ar}$  induced us to place the apparatus previously described<sup>1</sup> in a mine and make a preliminary search. This experiment served to place an upper limit on the flux of extraterrestrial neutrinos. These

3 counts in 18 days is probably entirely due to the background activity. However, if one assumes that this rate corresponds to real events and uses the efficiencies mentioned, the upper limit of the neutrino capture rate in 1000 gallons of  $\text{C}_2\text{Cl}_4$  is  $\leq 0.5$  per day or  $\varphi\bar{\nu} \leq 3 \times 10^{-34} \text{ sec}^{-1} ({}^{37}\text{Cl atom})^{-1}$ .

# First Measurement of Solar Neutrinos

Inverse beta decay  
of chlorine

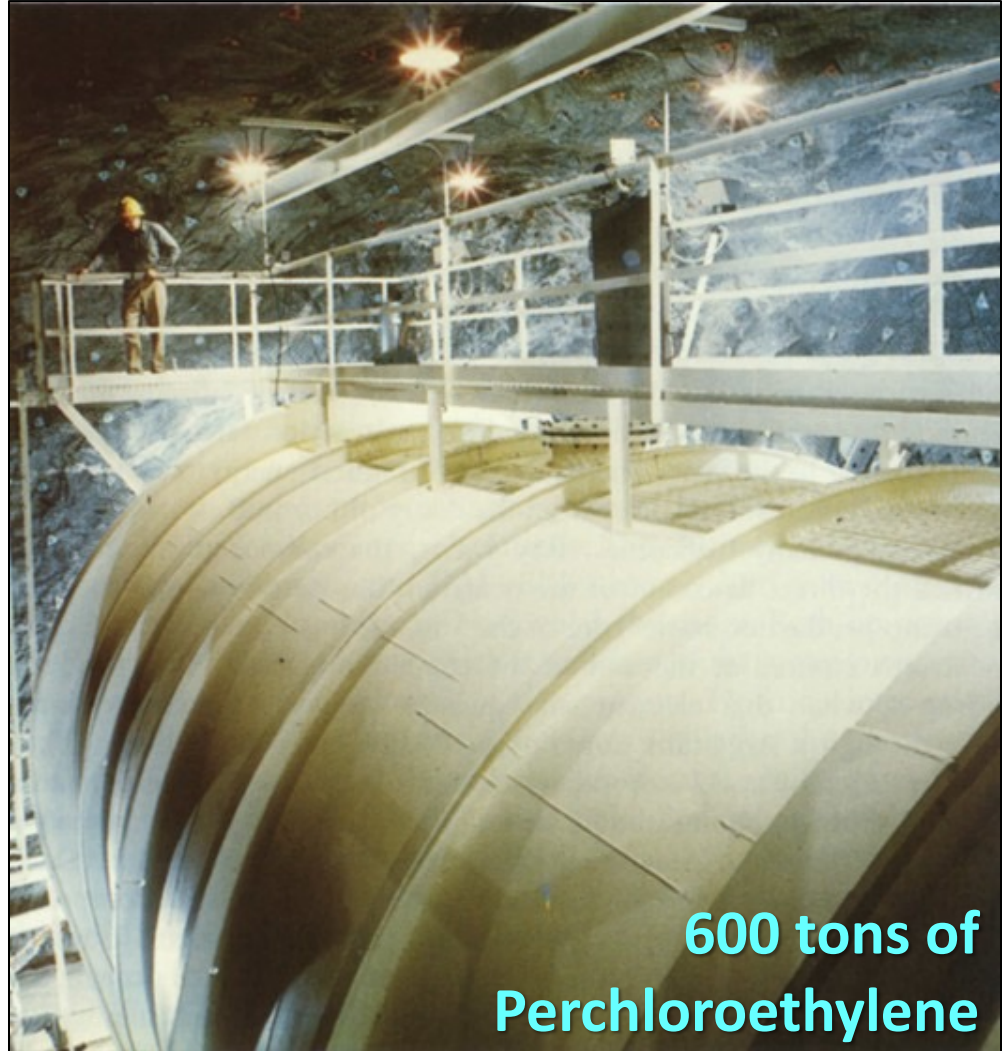
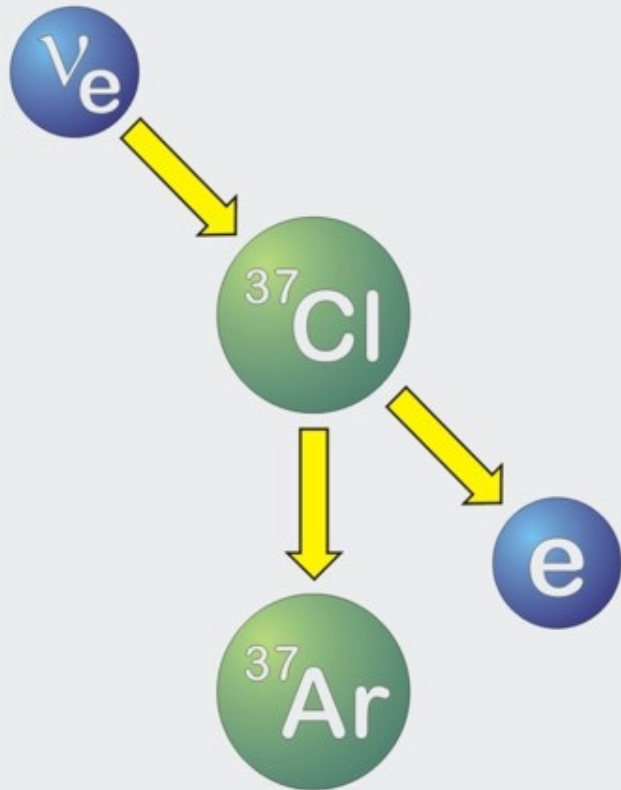

600 tons of  
Perchloroethylene

Homestake solar neutrino  
observatory (1967–2002)

# 2002 Physics Nobel Prize for Neutrino Astronomy

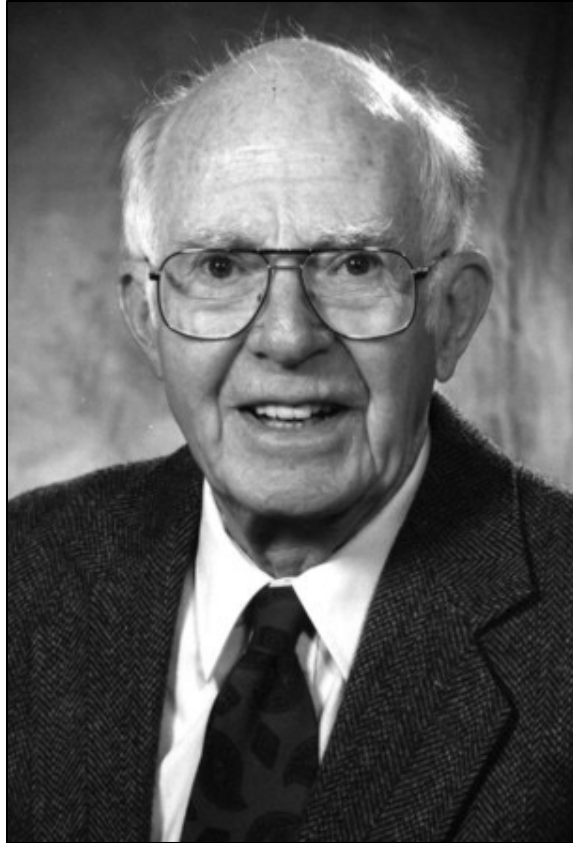

**Ray Davis Jr.**  
**(1914–2006)**



**Masatoshi Koshihara**  
**(\*1926)**



**“for pioneering contributions to astrophysics, in particular for the detection of cosmic neutrinos”**

# Neutrino interactions

- Weak interactions only, high energy  $\nu$

$$\nu_\mu + N \Rightarrow \mu + \text{hadrons}$$

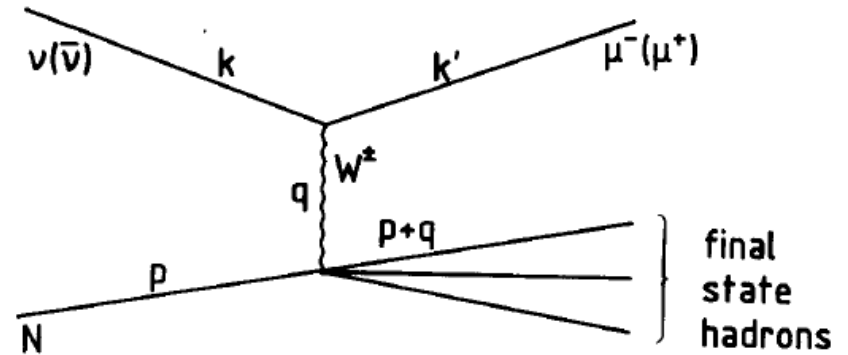

- Nuclear reactions used in experiments:

- |  |         |   |
|--|---------|---|
| 1. $\bar{\nu}_e + p \rightarrow e^+ + n$                 | CC      | ( $E_{\text{thr}} \approx 1.8$ MeV, reactor and geoch. expts)                         |
| 2. $\nu_e + (A, Z) \rightarrow e^- + (A, Z + 1)$         | CC      | ( $E_{\text{thr}}$ , radiochemical and geoch. expts)                                  |
| 3. $\nu_X + e^- \rightarrow \nu_X + e^-$                 | NC (CC) | (real time, $e^-$ direction Sun-Earth; $\nu$ energy dist.; $\nu$ flavour sensitivity) |
| 4. $\nu_X + (A, Z) \rightarrow \nu_X + (A, Z)^*$         | NC      | (Recoil energy + $E_\gamma$ ; $\nu$ flavour)  |
| 5. $\nu_e + d \rightarrow e^- + p + p$                   | CC      | (real time, anti-correlation with Sun direction)                                      |
| 6. $\nu_X + d \rightarrow \nu_X + p + n$                 | NC      | ( $\nu$ flavour sensitivity)  |
| 7. $\nu_X + N \rightarrow \mu, e, \tau + \text{hadrons}$ | CC      | (HE $\nu$ )   |
| 8. $\nu_X + N \rightarrow \nu_X + \text{hadrons}$        | NC      | (HE $\nu$ )   |

# Solar Neutrino Experiments

- Solar neutrino cross sections on matter

... **very small**  $\Rightarrow$  very radio-pure detectors of large mass in underground laboratories

- At these energies  $\sigma_\nu \sim 10^{-45} \text{ cm}^2$
- With flux of  $10^{10}/\text{cm}^2/\text{s}$  and  $10^{30}$  atoms  $\rightarrow$  1 event / day

$\rightarrow$  New unit: **"1 SNU"** =  $10^{-36}$  captures / target atom / s

## Experimental methods for solar $\nu$ detection

- Nuclear reactions used in experiments:

- |  |                 |   |
|--|-----------------|---|
| 1. $\nu_e + (A, Z) \rightarrow e^- + (A, Z+1)$   | <b>CC</b>       | ( $E_{\text{thr}}$ , radiochemical and geochemical expts)                             |
| 2. $\nu_X + e^- \rightarrow \nu_X + e^-$         | <b>NC (+CC)</b> | (real time, $e^-$ direction Sun-Earth; $\nu$ energy dist.; $\nu$ flavour sensitivity) |
| 3. $\nu_X + (A, Z) \rightarrow \nu_X + (A, Z)^*$ | <b>NC</b>       | (recoil energy + $E_\gamma$ ; $\nu$ flavour)  |
|  |                 | $\swarrow$<br>$(A, Z) + \gamma$ 's  |
| 4. $\nu_e + d \rightarrow p + p + e^-$           | <b>CC</b>       | (real time, anti-correlation with Sun direction, $E_{\text{thr}}=1.443 \text{ MeV}$ ) |
| 5. $\nu_X + d \rightarrow \nu_X + n + p$         | <b>NC</b>       | ( $\nu$ flavour sensitivity, $E_{\text{thr}}=2.226 \text{ MeV}$ )                     |

- Two types of experiments:

– Radiochemical experiments

- Homestake (1):  $\nu_e + {}^{37}\text{Cl} \rightarrow {}^{37}\text{Ar} + e^-$   
( $E_{\text{th}} = 0.814 \text{ MeV}$ )
- GALLEX/GNO, SAGE (1):  $\nu_e + {}^{71}\text{Ga} \rightarrow {}^{71}\text{Ge} + e^-$   
( $E_{\text{th}} = 0.233 \text{ MeV}$ )

– Scattering experiments

- Kamiokande, SuperK (light water) (2):  $\nu_X + e^- \rightarrow \nu_X + e^-$
- SNO (heavy water) (4):  $\nu_e + d \rightarrow p + p + e^-$   
(5):  $\nu_X + d \rightarrow \nu_X + n + p$
- BOREXINO (scintillator) (2):  $\nu_X + e^- \rightarrow \nu_X + e^-$

## Esperimenti della I generazione:

**Radiochimici** : **Cloro, Gallex, Sage**

**RealTime** : **Kamiokande**

# First Measurement of Solar $\nu$ : the $^{37}\text{Cl}$ exp.

## Radiochemical Experiment

## Inverse $\beta$ decay of $^{37}\text{Cl}$

- Reaction :  $\nu_e + ^{37}\text{Cl} \rightarrow e^- + ^{37}\text{Ar}$   $E_{\text{thr}} = 0.814 \text{ MeV}$
- Exp. site : gold mine of Homestake (4100 m.w.e.)
- Target : 615 tons of  $\text{C}_2\text{Cl}_4$  ,  $2.2 \times 10^{30}$  atoms of  $^{37}\text{Cl}$
- $\sigma_c$  :  $5 \times 10^{-46} \text{ cm}^2$  @ 1 MeV  
 $10^{-41} \text{ cm}^2$  @ 15 MeV

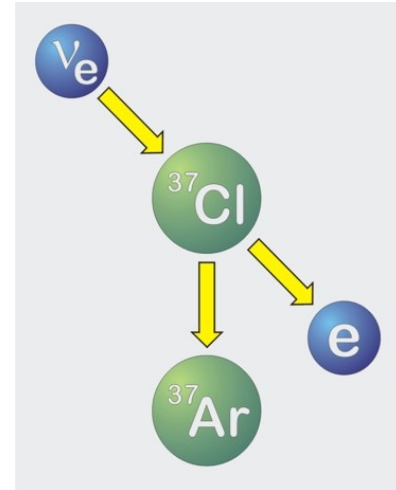

It is not sensitive to  $\nu_{pp}$  but to  $(^8\text{B})\nu$

- Procedure :
  - 35-150 days of exposition with  $0.1 \text{ cm}^3$  of STP of either  $^{36}\text{Ar}$  or  $^{38}\text{Ar}$ ;
  - Ar removed by flushing He;
  - Ar purified by gaschromatography and getters;
  - $^{37}\text{Ar}$  inserted into proportional counters for measuring (EC decay of  $^{37}\text{Ar}$ ,  $T_{1/2}=35.04$  days);
  - analysis with mass spectrometers to measure the amount of the extracted  $^{36}\text{Ar}$  or  $^{38}\text{Ar}$

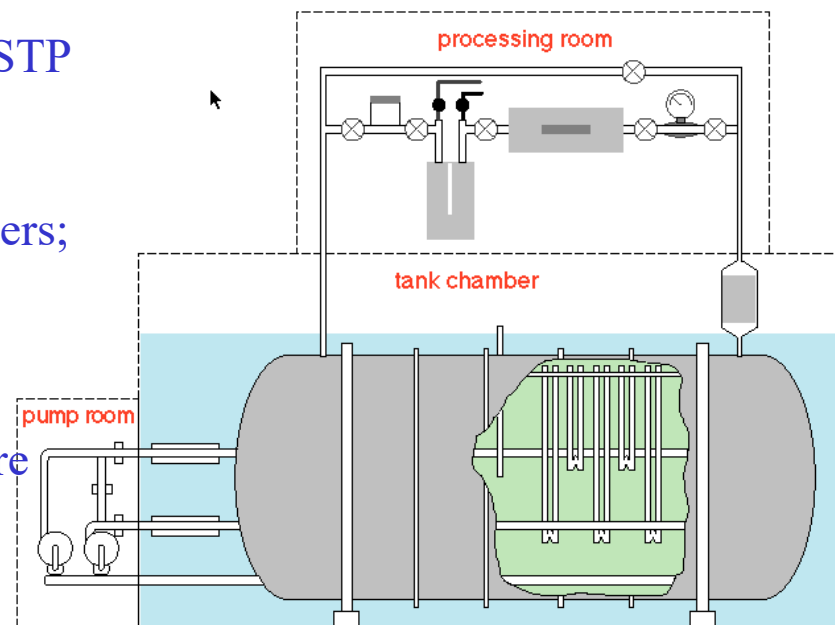

# Results of Chlorine Experiment (Homestake)

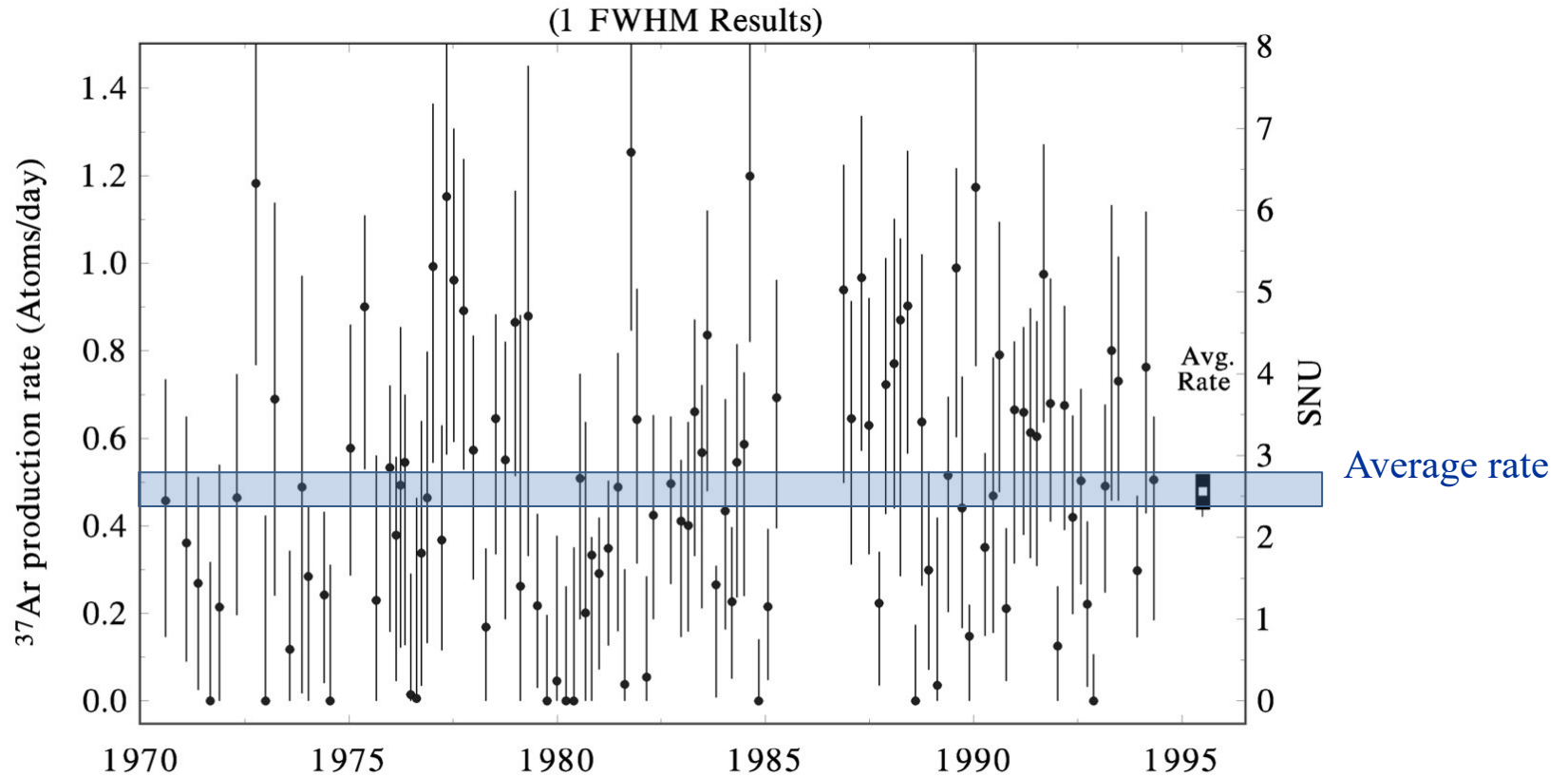

Average (1970-1994)  $2.56 \pm 0.16_{\text{stat}} \pm 0.16_{\text{sys}}$  SNU

Theoretical Prediction 6-9 SNU

“Solar Neutrino Problem” since 1968

# Kamiokande

confirms the deficit of high energy solar  $\nu$

- Reaction :  $\nu + e^- \rightarrow \nu + e^-$  exp. Thr.:  $E = 7.5 \text{ MeV}$
- Exp. site : Kamioka mine (2700 m.w.e.) ↻ Sensitive to  $(^8\text{B})\nu$
- Target : 680 tons of  $\text{H}_2\text{O}$  (fiducial volume),  $2.27 \times 10^{32} e^-$

→ charged particles detected by Cerenkov light

Identification of events due to  $\nu_e$ :

- low energy events
- fiducial volume cut ( $\gamma, n$ )
- cosmic rays cut
- correlation Earth-Sun

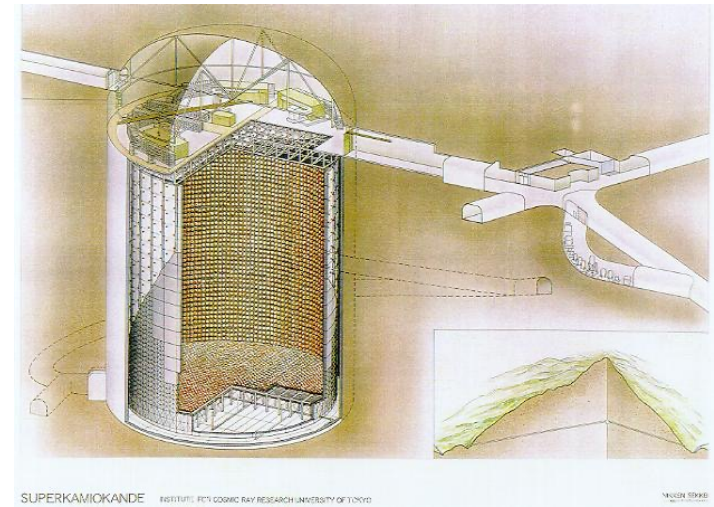
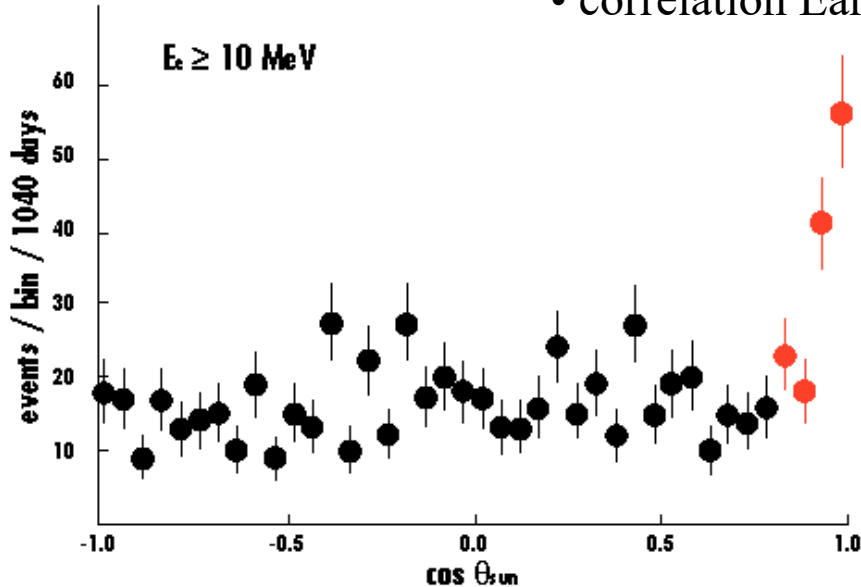

$R_{\text{expected}} = 0.3 \text{ events/days/680 tons}$   
( $>10 \text{ MeV}$ )

Kam. II and III:

**Data/SSM =  $0.50 \pm 0.06 \pm 0.06$**

# Cherenkov Effect

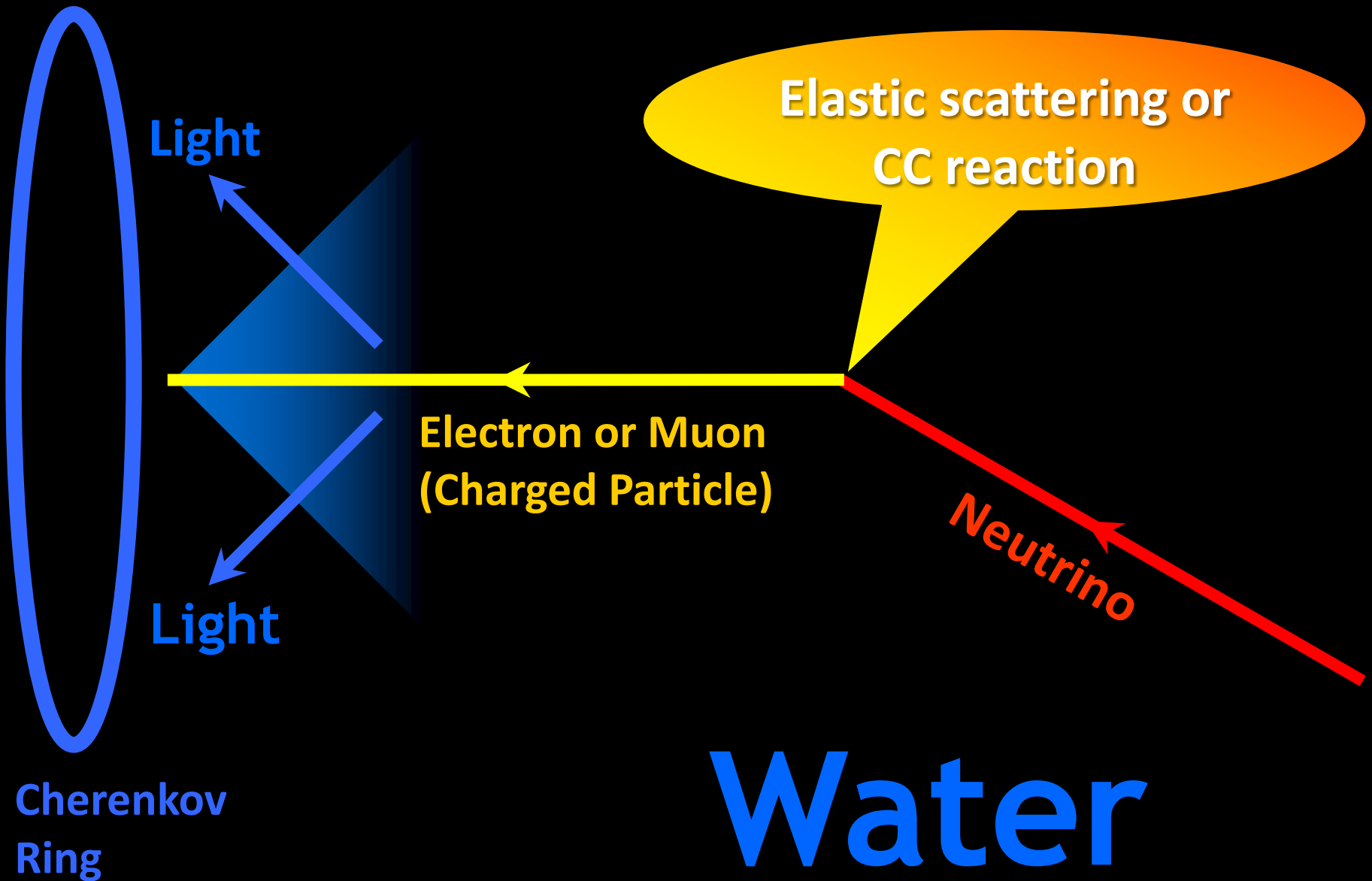

**meccanismo coerente di produzione di luce Cherenkov**

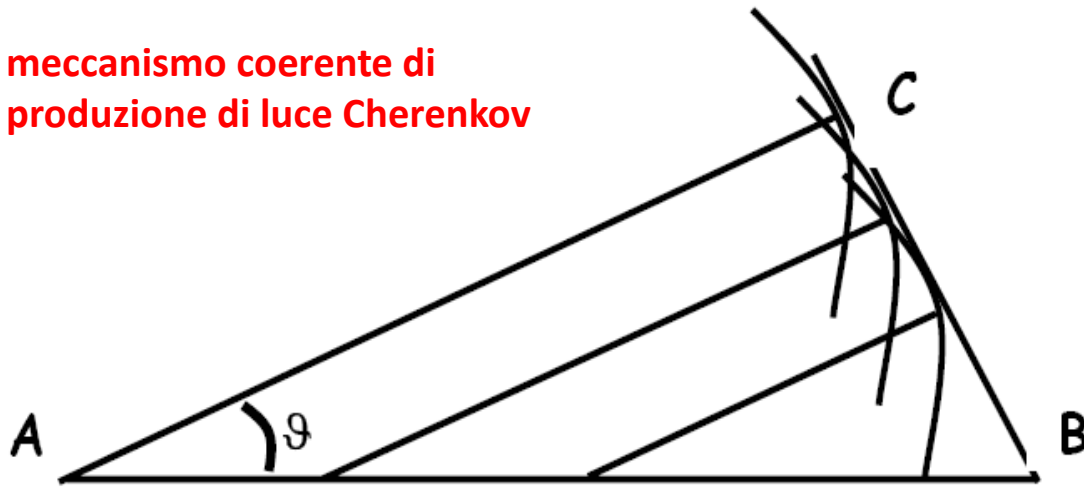

$$AB = \beta c \Delta \tau$$

$$AC = c/n \Delta \tau = AB \cos \vartheta$$

$n$  = indice di rifrazione del mezzo

$$\cos \vartheta = \frac{AC}{AB} = \frac{c \Delta \tau}{n \beta c \Delta \tau} = \frac{1}{n \beta}$$

Poiché  $\cos \vartheta \leq 1$  si ricava che deve essere  $\beta \geq 1/n$

I contatori Cherenkov producono luce solo per particelle con  $\beta \geq 1/n$  e funzionano egregiamente per esempio per distinguere, a parità di energia cinetica, protoni, pioni ed elettroni.

$$T \geq \frac{m}{\sqrt{1 - \beta_{\min}^2}} - m = m \left( \frac{1}{\sqrt{1 - \beta_{\min}^2}} - 1 \right)$$

**Caratteristiche di alcuni materiali usati come rivelatori Cherenkov**

Material	$n$	Threshold $\beta$	Protons	Pions	Electrons
Liq. N <sub>2</sub>	1.205	0.830	760 Mev	112 Mev	410 kev
Liq. O <sub>2</sub>	1.221	0.819	710 Mev	104 Mev	380 kev
FC-75*	1.277	0.782	580 Mev	86 Mev	315 kev
Water	1.332	0.751	500 Mev	73 Mev	265 kev

\* A fluorochemical available from Minnesota Mining & Mfg. Co. (Composition C<sub>8</sub>F<sub>10</sub>O).

In H<sub>2</sub>O:

- $\vartheta_{\max} = 41$  gradi

- $T \geq 0.514m$

# GALLEX

- Reazione :  $\nu_e + {}^{71}\text{Ga} \rightarrow e^- + {}^{71}\text{Ge}$   $E_{\text{thr}} = 0.233 \text{ MeV}$   $\sim 1 \text{ catt./d attesa}$   
(verifica sui  $\mathbf{V}_{\text{pp}}$   $E_{\text{max}} = 420 \text{ keV}$ )
- Sito sper. : Laboratori sotterranei del Gran Sasso (3300 m.w.e.)
- Bersaglio : 30 tons di Gallio in  $\text{GaCl}_3 + \text{HCl}$
- Gallex/Gno (1991/2003)



LNGS

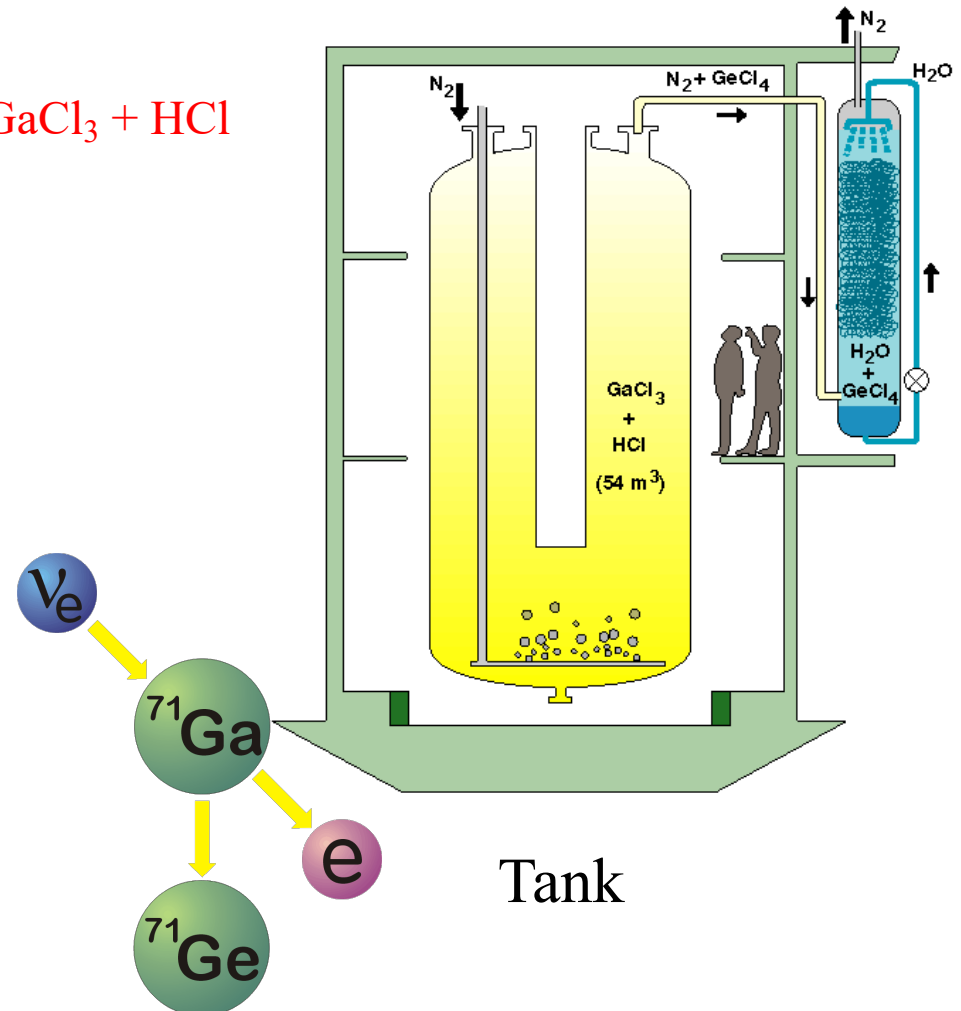

Tank

# GALLEX/GNO

- **Purpose:** measurement of the low energy solar neutrino interaction rate which is related to the sun luminosity (*i.e. model-independent*), with an accuracy of 5 SNU (**GNO**) and investigation of its time dependence on a solar cycle with a sensitivity  $\sim 15\%$  (**GNO**).
- **Basic interaction:**  $\nu_e + {}^{71}\text{Ga} \rightarrow e^- + {}^{71}\text{Ge}$   $E_{\text{thr}} = 0.233 \text{ MeV}$   $\sim 1.2 \text{ capture/day}$  expected by SSM  
 $\swarrow$   
 ${}^{71}\text{Ga}$  EC,  $\tau = 16.49 \text{ days}$
- **Exp. site:** Gran Sasso underground laboratory (3300 m.w.e.)
- **Target:** 103 tons of  $\text{GaCl}_3$  acidic solution  $\Rightarrow$  30 tons of  ${}^{\text{nat}}\text{Ga}$  (**12 tons of  ${}^{71}\text{Ga}$** ) in  $\text{GaCl}_3 + \text{HCl}$
- **Technique:** **radiochemical**, chemical extraction of  ${}^{71}\text{Ge}$  every 3-4 weeks; **detection of  ${}^{71}\text{Ge}$**  decay with gas proportional counters  $T_{1/2} = 11.43 \text{ days}$
- **Expected signal (SSM):**  $\sim 9$   ${}^{71}\text{Ge}$  counts detected per extraction

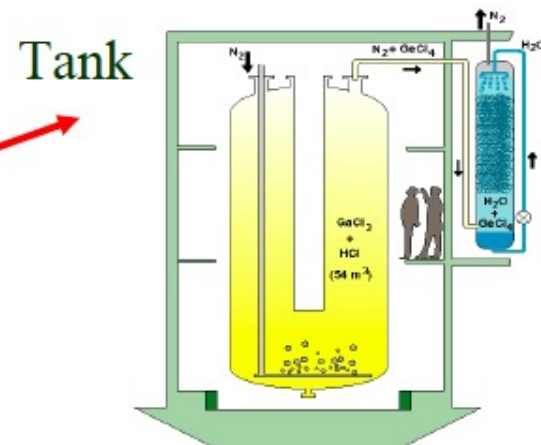

# Extraction and counting procedures - 1

- 3-4 weeks of exposure to the solar neutrinos (SR) or 1 day for *blank run* (BR).
- $^{71}\text{Ge}$  ( $\text{GeCl}_4$ ) extracted in water fluxing  $\sim 3000 \text{ m}^3$  of nitrogen in the solution
- $^{71}\text{Ge}$  ( $\sim 95\%-98\%$ ) converted in  $\text{GeH}_4$  (gas) and used together with Xe gas to fill a miniaturized proportional counter
- Counting of the  $^{71}\text{Ge}$  nuclei through its decays  $T_{1/2}=11.43$  days
- Expected signal (SSM): 1.2 n inter./day, but due to decay during exposure + ineff.  $\sim 9$   $^{71}\text{Ge}$  counts detected per extraction

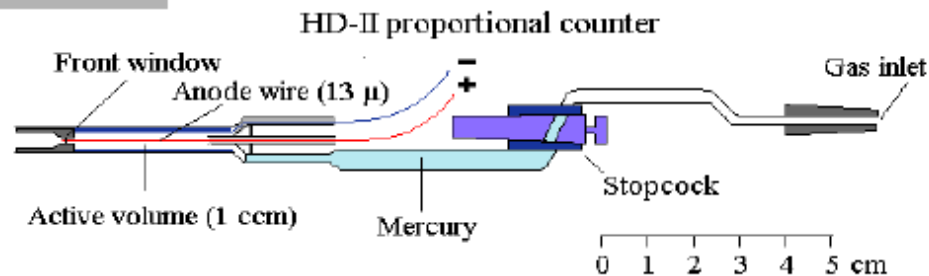
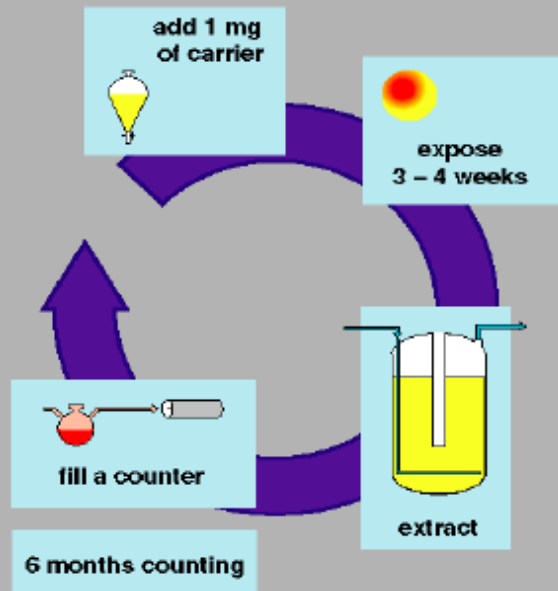

Miniaturized Proportional Counter



The columns



Proportional counter



The synthesis line

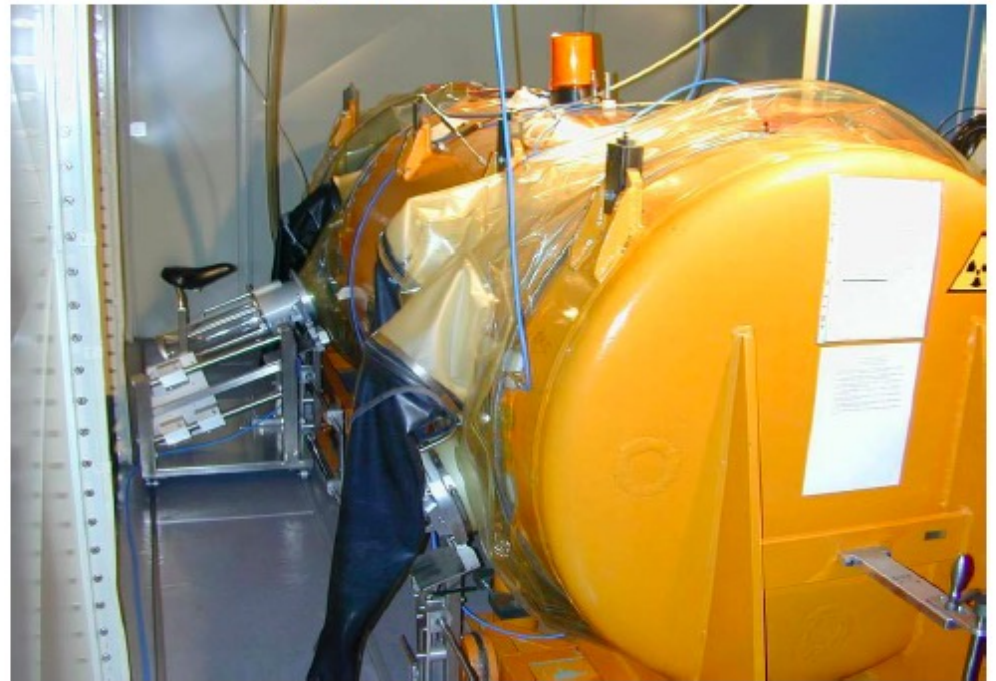

Shielding

# Extraction and counting procedures - 2

## Decay processes for $^{71}\text{Ge}$ detection

$^{71}\text{Ge}$  (EC)  $\rightarrow$   $^{71}\text{Ga}^*$   $\rightarrow$   $^{71}\text{Ga}$  ( $t_{1/2} = 11.4$  d)

	%	Auger (keV)	X-ray (keV)
K	41.5	10.37	-
	41.2	1.12	9.25
	5.3	0.11	10.26
L	10.3	1.30	-
M	1.7	0.16	-

$\rightarrow$  fast pulses with the respect to those due to natural radioactivity

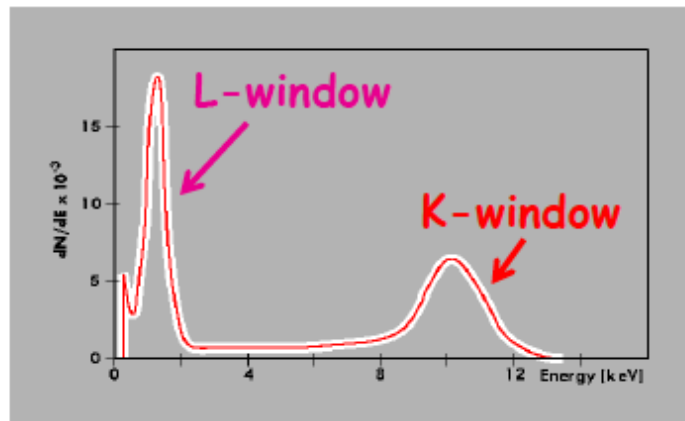

Expected energy distribution

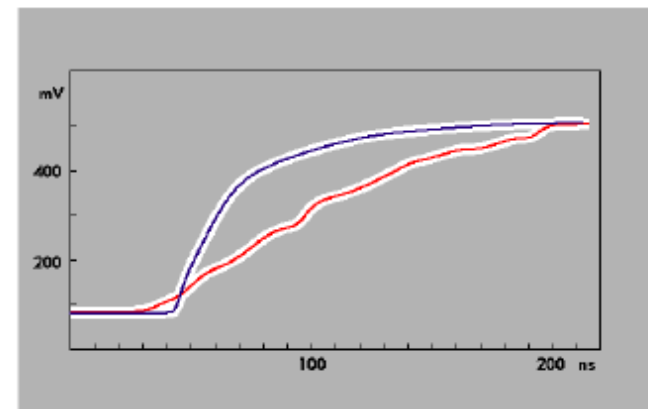

**RED:** background pulse  
**BLU:** fast event pulse of  $^{71}\text{Ge}$  decay

# Risultati dell' esperimento GALLEX

Rate di cattura predetta  
dal SSM per il  $^{71}\text{Ga}$  \*

Sorgente	Rate (SNU)
pp	70.8
pep	3.0
hep	0.06
$^7\text{Be}$	34.3
$^8\text{B}$	14.0
$^{13}\text{N}$	3.8
$^{15}\text{O}$	6.1
$^{17}\text{F}$	0.06
<b>TOTAL</b>	<b>132 SNU</b>

## GALLEX RESULTS

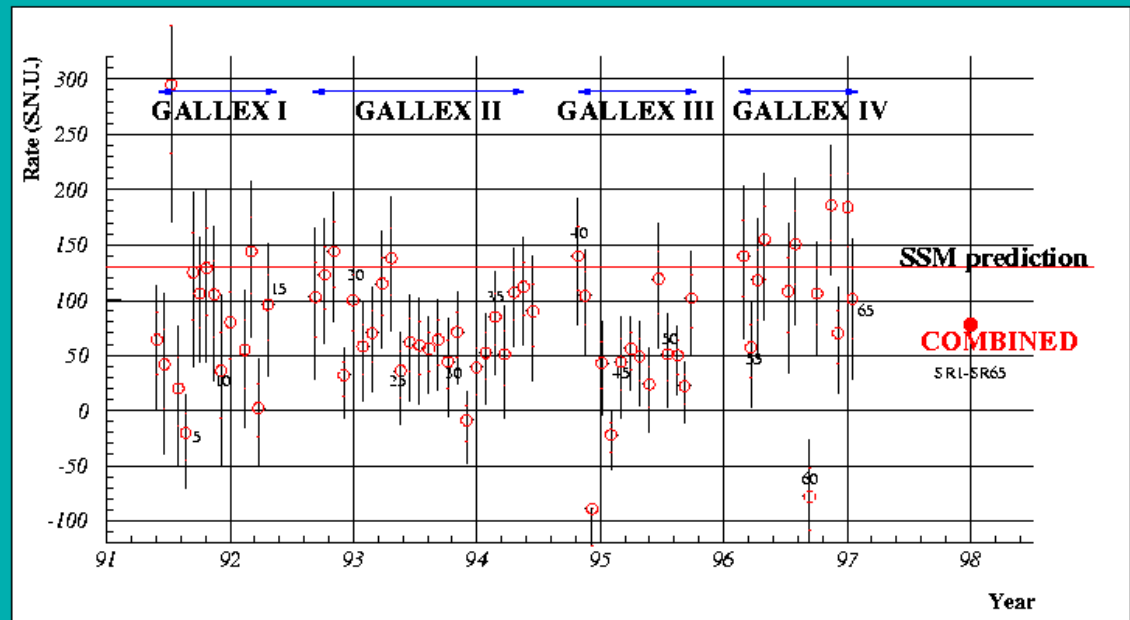

**Combined Result (SR1-SR65):  $77.5 \pm 6.2$  (stat)  $^{+4.3}_{-4.7}$  (sys)**

Phys.Lett. B447 (1999) 127

$$\text{Dati/SSM} = 0.59 \pm 0.06$$

\*Bahcall 1990

# $\nu$ 's from the SUN

## Solar neutrino energy spectrum

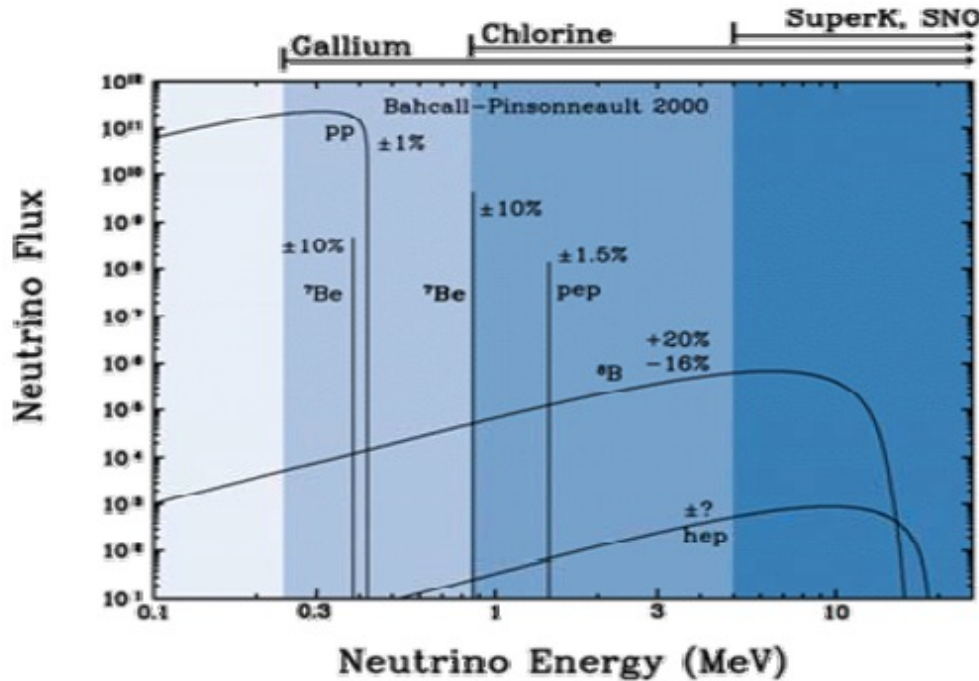

## $\nu$ signal composition

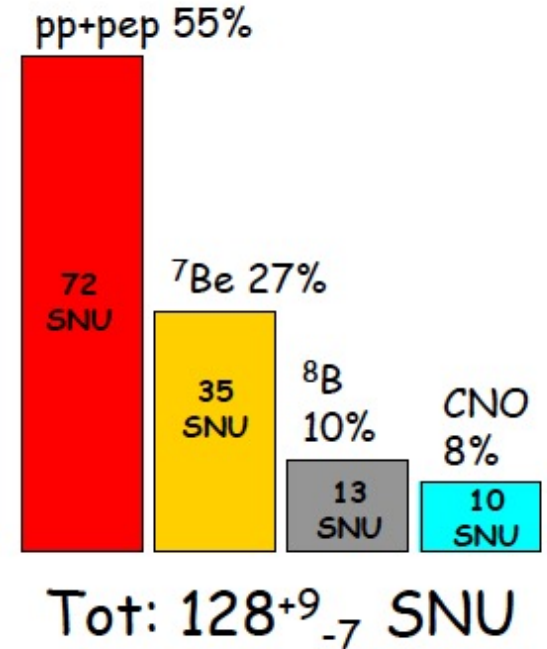

# GALLEX – Energy and rise time distributions

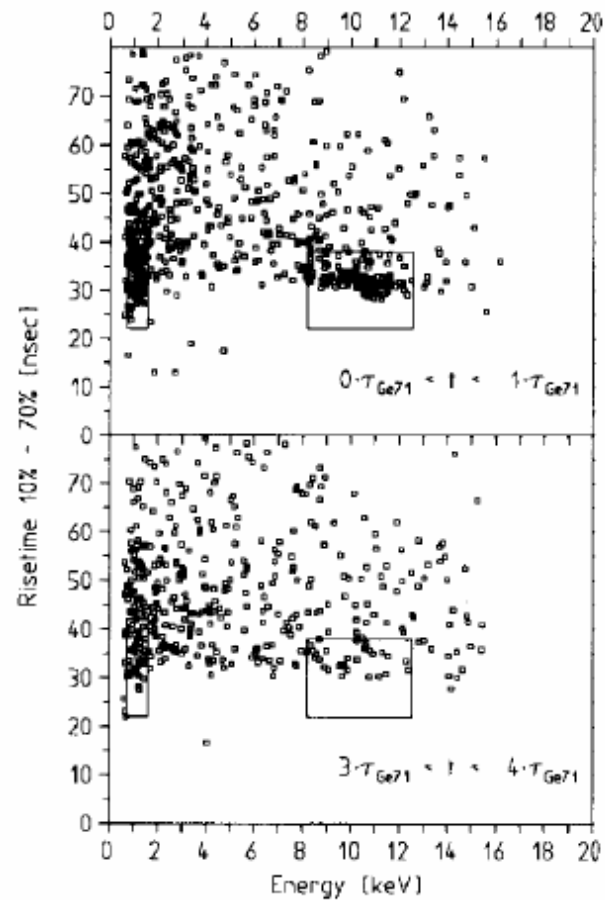
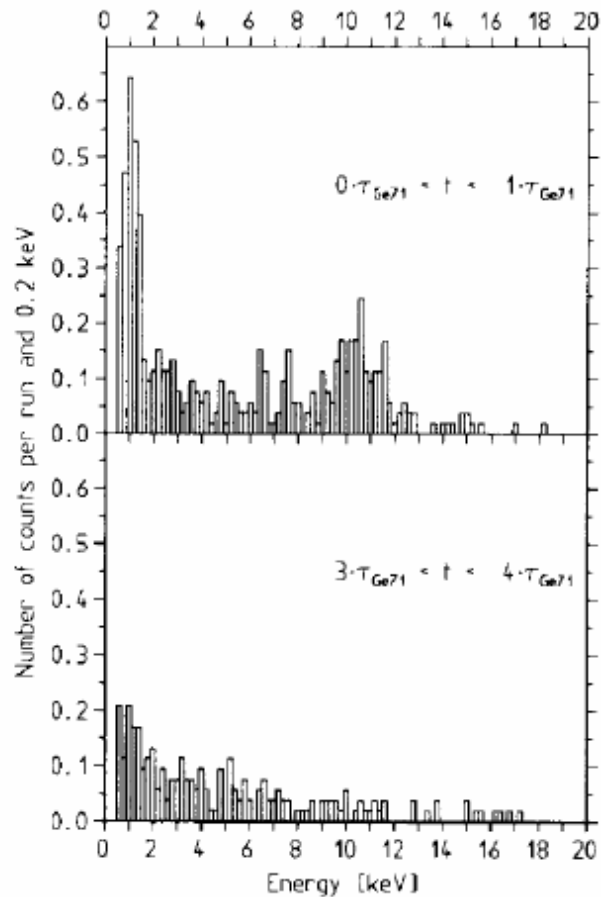

Few hundred of events in  
several years of running

GALLEX I + II + III

# Energy distribution of fast events

GNO

Energy distribution of fast events  
GNO : SR1 – SR 43

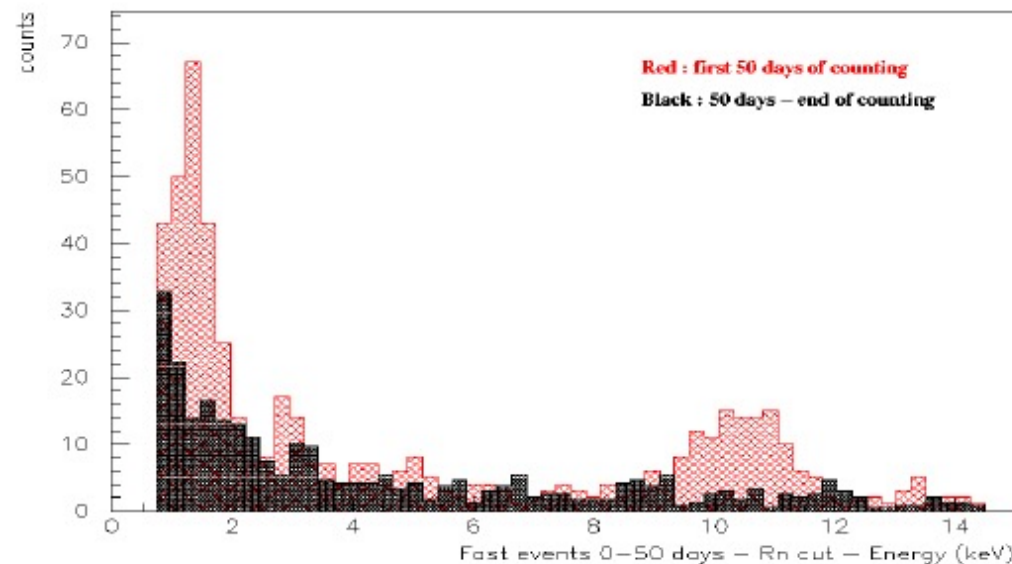

$t < 50$  days

(50 d  $\sim 3\tau$ )



$t > 50$  days

- $L_{\text{only}}$   $\rightarrow 69.6 \pm 10.3$  SNU
- $K_{\text{only}}$   $\rightarrow 62.2 \pm 8.2$  SNU
- $L+K$   $\rightarrow 65.2 \pm 7.1$  SNU (N.N.)
- $L+K$   $\rightarrow 69.4 \pm 7.1$  SNU (R.T.)

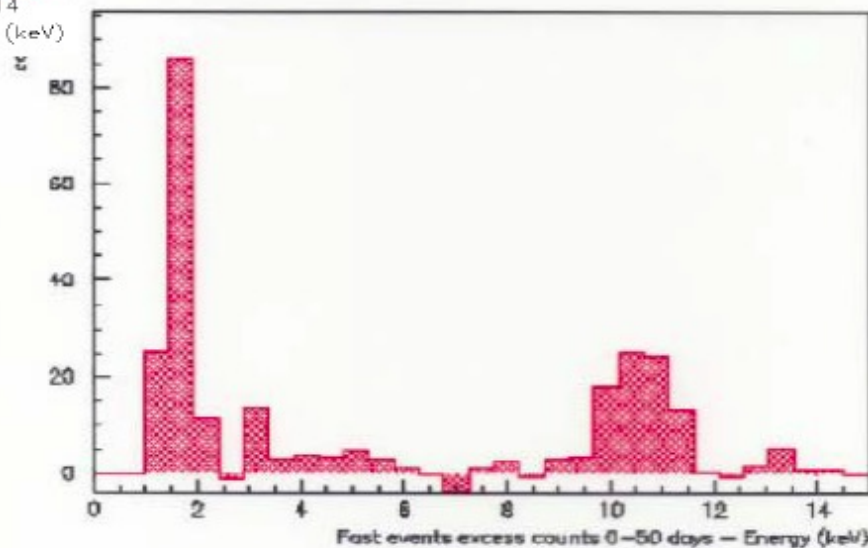

### Time dist. of selected events

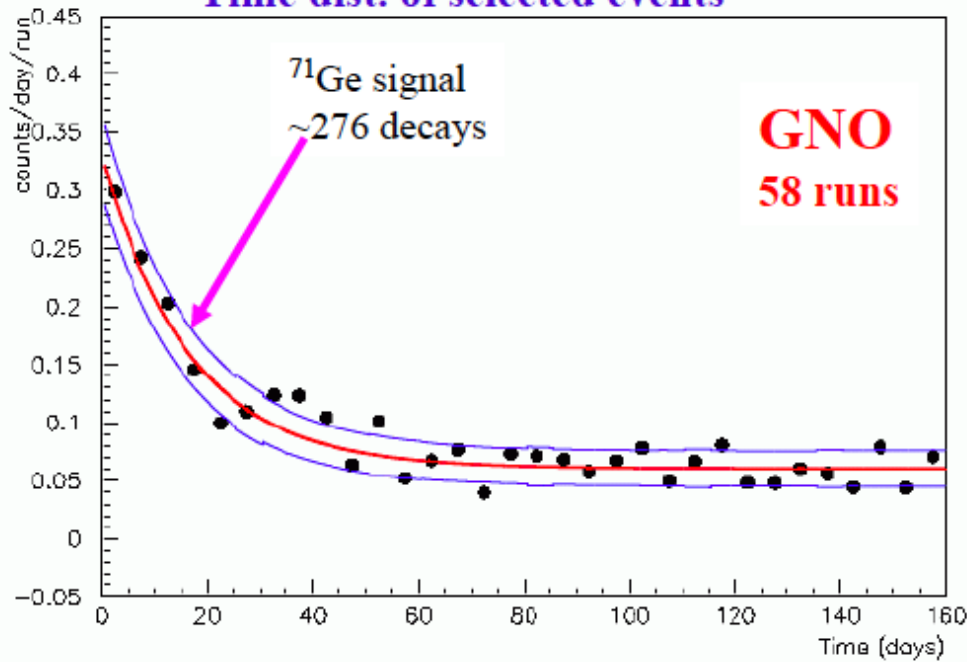

$$\tau(^{71}\text{Ge}) = 16.6 \pm 2.1 \text{ d}$$
$$\tau_{\text{true}}(^{71}\text{Ge}) = 16.49 \text{ d}$$

### Time dist. of selected events.

**GALLEX**  
65 runs

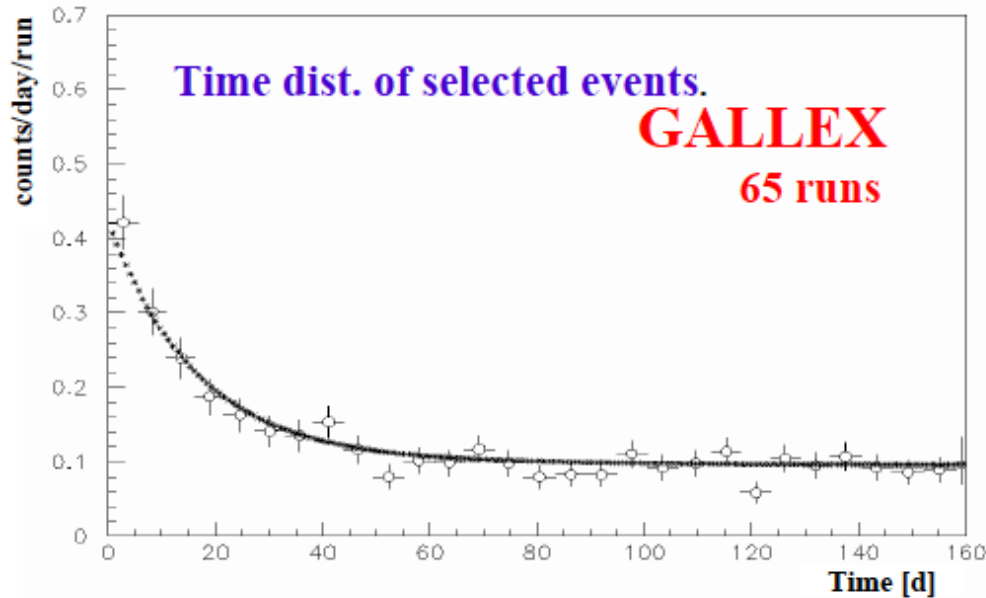

**Reduction of the bckg  
GNO vs Gallex 30%**

**from 0.1 c/day/run to 0.07 c/day/run**

# Gallex + GNO results: Davis plot

Total exposure time: 3307 d

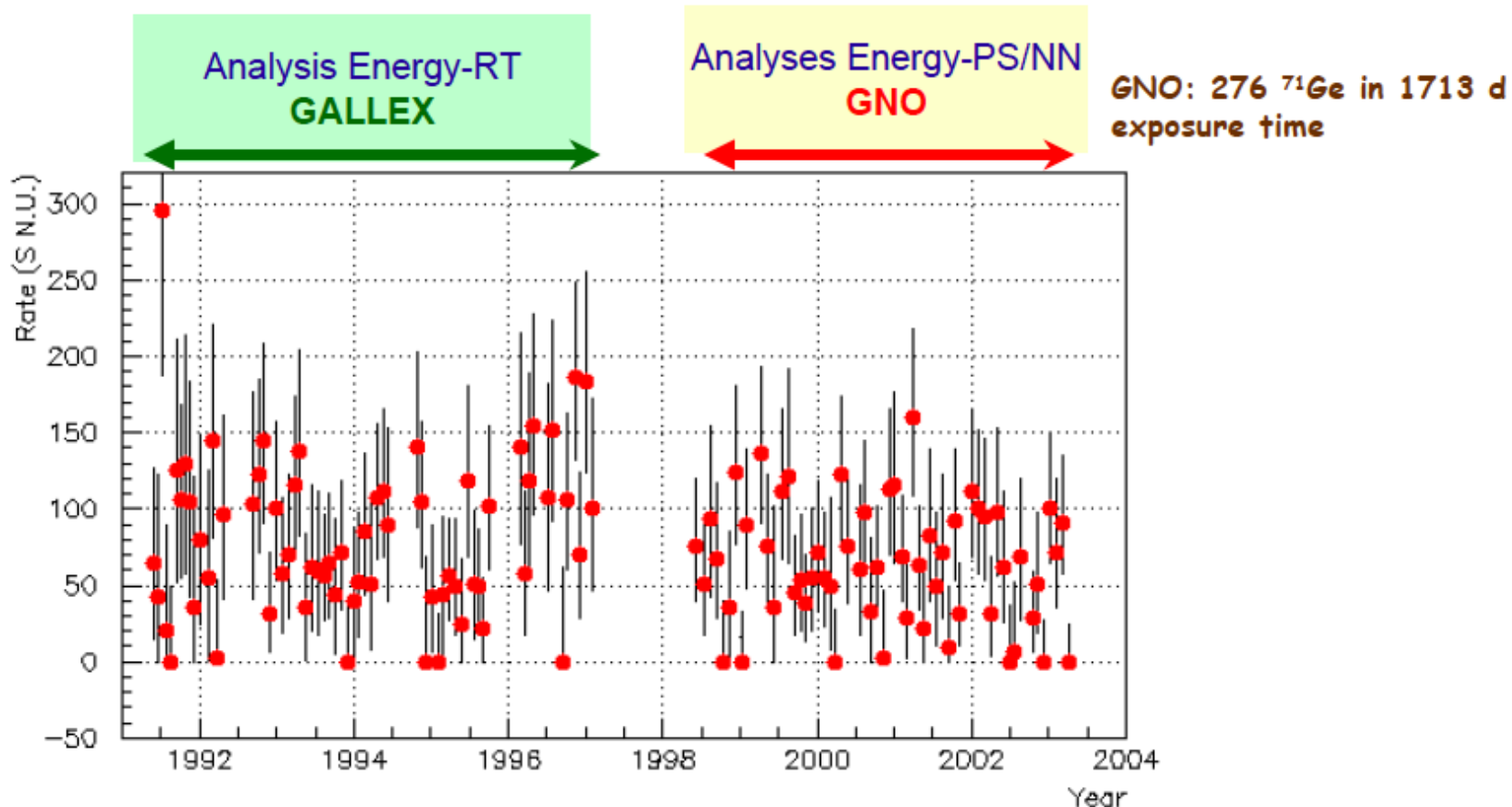

**GALLEX**

**65 SR**

**$77.5 \pm 6.2$  (stat)  $\pm 4.5$  (sys) SNU**

**GNO**

**58 SR**

**$62.9 \pm 5.4$  (stat)  $\pm 2.5$  (sys) SNU**

**GALLEX + GNO**

**123 SR**

**$69.3 \pm 4.1$  (stat)  $\pm 3.6$  (sys) SNU**

# GALLEX and GNO legacy

- Construction of the detector: 1986-1990
- GALLEX runs: May 14, 1991 – Jan 23, 1997
- First  $^{51}\text{Cr}$   $\nu$  source expt: Jun 1994 – Oct 1994
- Second  $^{51}\text{Cr}$   $\nu$  source expt: Oct 1995 – Feb 1996
- Tests with  $^{71}\text{As}$ : Feb 1997 – Apr 1997
- Improvements towards GNO: Apr 1997 – Apr 1998
- GNO runs: May, 20 1998 – Apr, 9 2003

## GALLEX legacy:

- observation of pp fusion in the solar core
- definitive deficit of  $^7\text{Be}$  (or pp)  $\nu$  not explainable by solar physics
- reliability of the radiochemical (solar- $\nu$ ) experiments ( $\nu$ -sources, As-test)

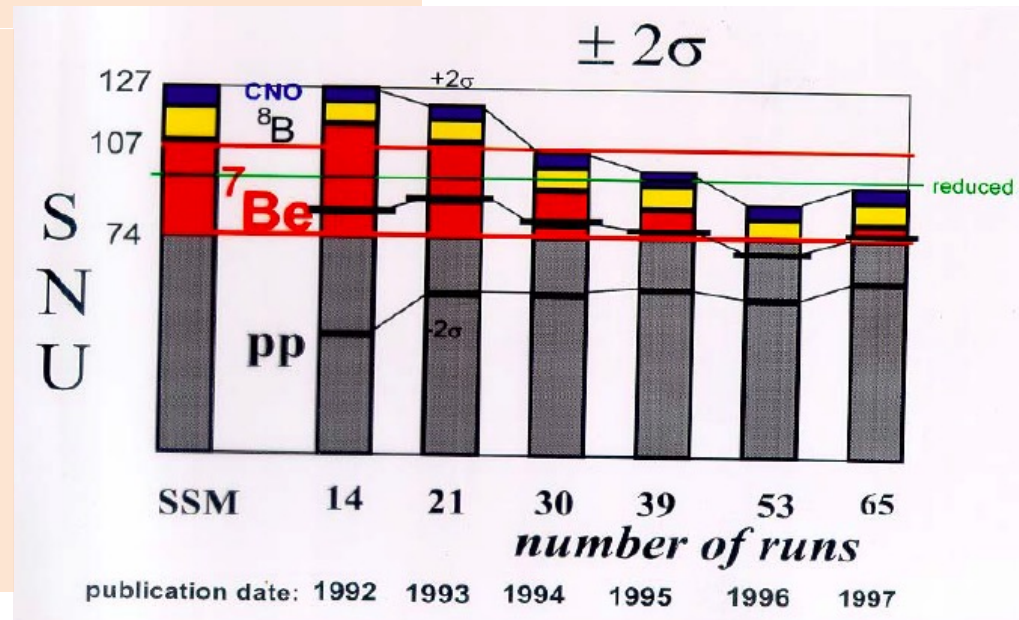

# Why a $\nu$ source experiment?

To place trustworthiness of the experimental techniques (excluding unforeseen effects)

How? Exposing the target to  $\nu$ 's of suitable energy from source of known activity in the same condition than in the solar exposures

## Needs

>50 PBq

build a  $\nu$  source with activity allowing a precision on  $\approx 9\%$  in the measurements

$^{51}\text{Cr}$

$\nu$  energy close to solar  $\nu$  detected in the experiments

$(27.706 \pm 0.007)$

$T_{1/2}$  sufficient to transport the source and perform the experiment

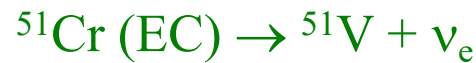
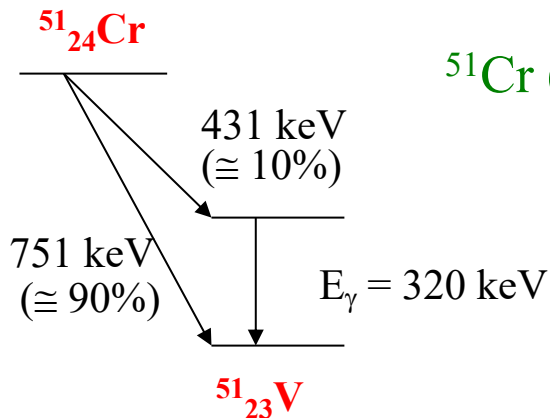

$$T_{1/2} = 27.7 \text{ d}$$

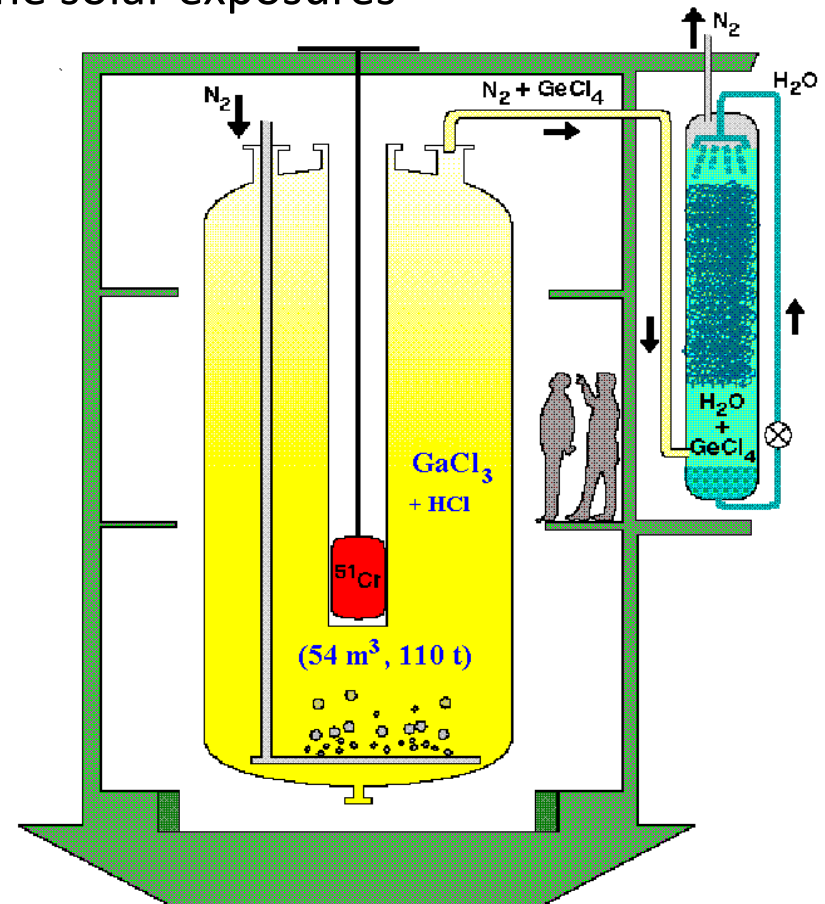

# Verifica dell'affidabilità del procedimento di misura in Gallex

- Esposizione del rivelatore ad una **sorgente di  $\nu$**  di energia e di attività nota
- massa  $\cong 35.5$  kg, attività  $\cong 2$  MCi

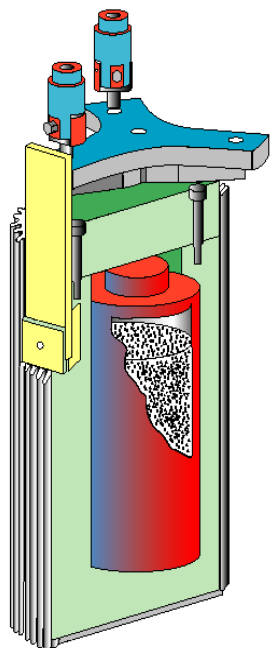

Cromo arricchito in  $^{50}\text{Cr}$  è stato attivato nel reattore nucleare di Grenoble:

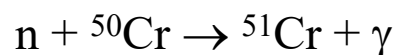

Irradiators with enriched chromium (top) and equipped for neutron measurement (bottom)

Dummy (top) and irradiator with enriched chromium (bottom)

0 cm 50

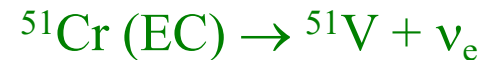

$T_{1/2} = 27.7$  d

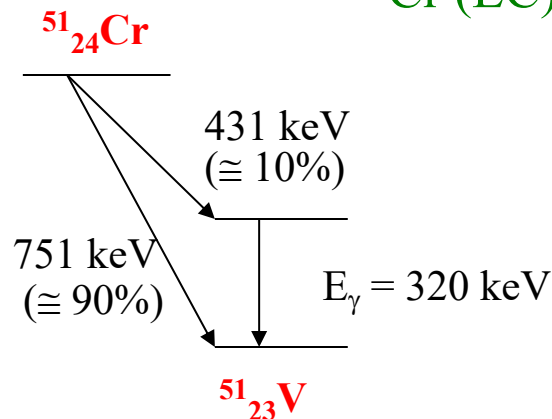

Isotopic composition of chromium and thermal neutron capture cross sections (measured at 2200 m/s)

	Isotopic composition of natural Cr [%]	Isotopic composition of the enriched Cr used in GALLEX [%]	Thermal neutron capture cross sections [b] [15]
${}^{50}\text{Cr}$	4.35	38.6	15.9
${}^{52}\text{Cr}$	83.8	60.7	0.76
${}^{53}\text{Cr}$	9.50	0.7	18.2
${}^{54}\text{Cr}$	2.35	< 0.3	0.36

# Response of GALLEX to $^{51}\text{Cr}$ source expts

Direct measurements of the activity of the two sources with different methods.

Method (Laboratory)	Value (PBq)	
	First source	Second source
Ionization chamber (Saclay)	$61.3 \pm 1.2$	$67.4 \pm 1.3$
Ge spectroscopy (Heidelberg)	$63.2 \pm 1.3$	$68.3 \pm 1.3$
Ge spectroscopy (Karlsruhe)	$63.1 \pm 1.3$	$70.2 \pm 1.3$
Ge spectroscopy (BNL)	$63.1 \pm 1.5$	$70.1 \pm 1.3$
Calorimetry (Grenoble/Saclay)	$61.9 \pm 3.0$	$65.2 \pm 6.0$
Neutronics (Grenoble)	$64.4 \pm 5.2$	$75.1 \pm 6.0$
Gamma scanning (Grenoble)	$64.0 \pm 5.2$	
Vanadium content (BNL)	$65.2 \pm 1.2$	$67.1 \pm 2.5$
Vanadium content (Karlsruhe)	$66.0 \pm 2.1$	$72.3 \pm 3.2$
Weighted mean	$63.4 \pm 0.5$	$69.1 \pm 0.6$
Best estimate	$63.4^{+1.1}_{-1.6}$	$69.1^{+3.3}_{-2.1}$

$$T_{1/2} = 27.7 \text{ d}$$

- Radiochemical techniques are reliable: it is possible to extract few atoms from 30 tons and to count their decays

- First observation of low energy  $\nu$  from artificial terrestrial source
- Confirmation of solar  $\nu$  deficit
- General check of the experiment

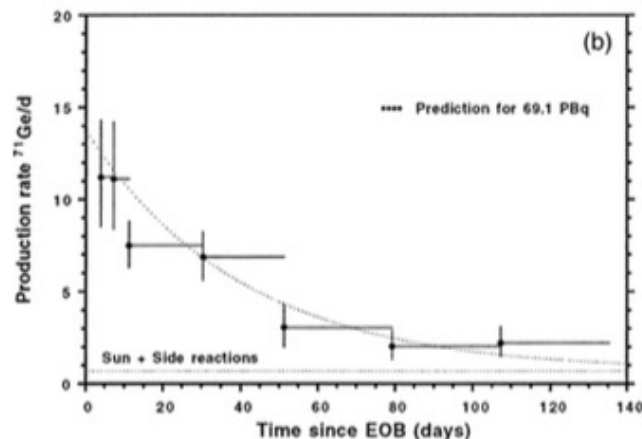
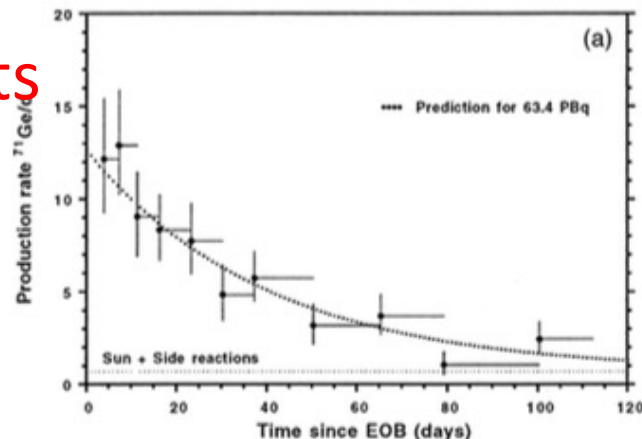

Characteristics and results of the two source experiments. The combined value for the ratio of the activity deduced from the  $^{71}\text{Ge}$  measurement and of the activity directly measured, R, is given in the last column.

	First source	Second source	Two sources
Start of exposure	June 23, 1994	October 10, 1995	
End of exposure	October 5, 1994	February 14, 1996	
Number of extractions	11	7	
End of counting	May 2, 1995	September 17, 1996	
Activity directly measured (PBq)	$63.4^{+1.1}_{-1.6}$	$69.1^{+3.3}_{-2.1}$	
Activity deduced from $^{71}\text{Ge}$ (PBq)	$64.0^{+7.3}_{-6.9}$	$57.9^{+7.6}_{-7.2}$	
Ratio R	$1.01^{+0.12}_{-0.11}$	$0.84^{+0.12}_{-0.11}$	$0.93 \pm 0.08$

$$(1\text{PBq} = 10^{15}\text{Bq} = 27.0 \text{ kCi})$$

$0.93 \pm 0.08$

# <sup>71</sup>As tests in GALLEX

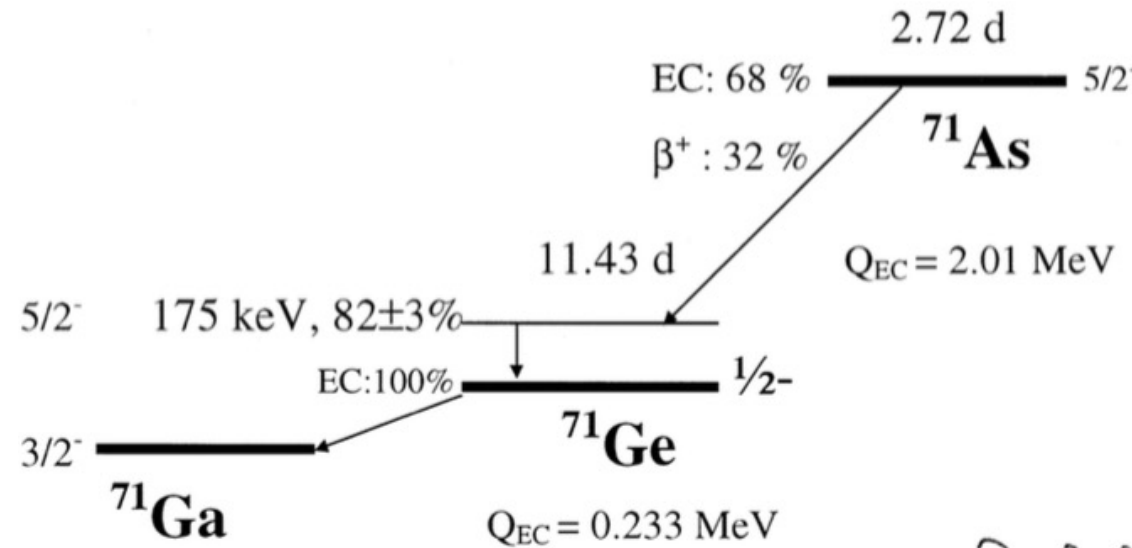

- Introduction of about 10<sup>5</sup> atoms of <sup>71</sup>As inside the tank in the solution
- Repeated tests under variable conditions with respect to:
  - Method and magnitude of carrier addition
  - Mixing and extraction conditions
  - Standing time

Recoil kinematics for solar neutrinos and for <sup>71</sup>As-decay in the GALLEX target

<sup>71</sup> Ge-production process	energy of emitted particles [MeV]	recoil energy E <sub>R</sub> of <sup>71</sup> Ge-atom (or nucleus)
-------------------------------------	-----------------------------------	--

*Solar neutrino capture:*

$\nu_e + {}^{71}\text{Ga} \rightarrow {}^{71}\text{Ge} + e^-$		
pp-neutrinos (~ 56% of expected rate)	0-0.19	≤ 1.5 eV
<sup>7</sup> Be-neutrinos (~ 27% of expected rate)	0.63 (90%)	7.9 eV
	0.15 (10%)	1.3 eV
<sup>8</sup> B = neutrinos (~ 10% of expected rate)	$\langle \sigma \cdot \phi \rangle_{\text{max}}$ at ≈ 10	→ 830 eV

*Arsenic in-situ decay:*

electron capture (68%): ${}^{71}\text{As} + e^- \rightarrow {}^{71}\text{Ge}^* + \nu$	1.838	25.6 eV
positron decay (32%): ${}^{71}\text{As} \rightarrow {}^{71}\text{Ge}^* + e^+ + \nu$	0.813	≤ 11.3 eV
γ-emission (82%): ${}^{71}\text{Ge}^* \rightarrow {}^{71}\text{Ge} + \gamma$	0.175	0.23 eV

- To exclude withholdings (classical or “hot-atom” effects)

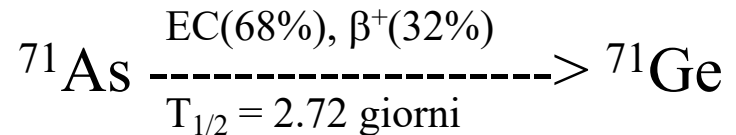

**Recovery factor = (99.9 ± 0.8) %**

# SAGE Soviet-American Gallium Experiment



Sensitive to pp fusion in sun.

50 metric tons of Gallium  
They extract a *few tens of atoms* of Germanium

Measured:  $77 \pm 6 \pm 3$  SNU  
Predicted:  $123 + 9 - 7$  SNU

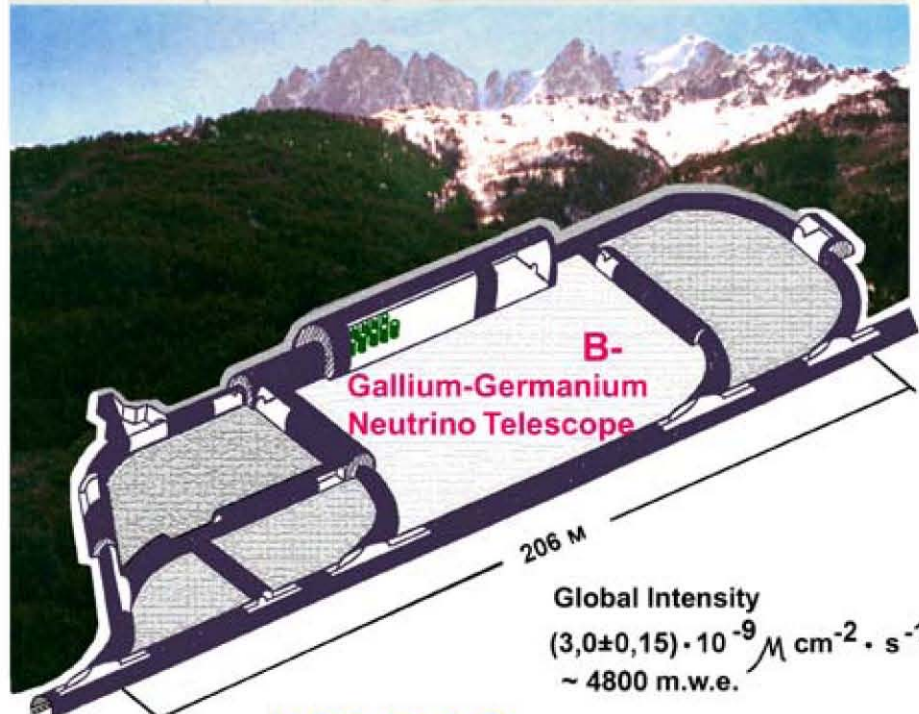

Global Intensity  
 $(3,0 \pm 0,15) \cdot 10^{-9} \mu\text{m cm}^{-2} \cdot \text{s}^{-1}$   
 $\sim 4800 \text{ m.w.e.}$

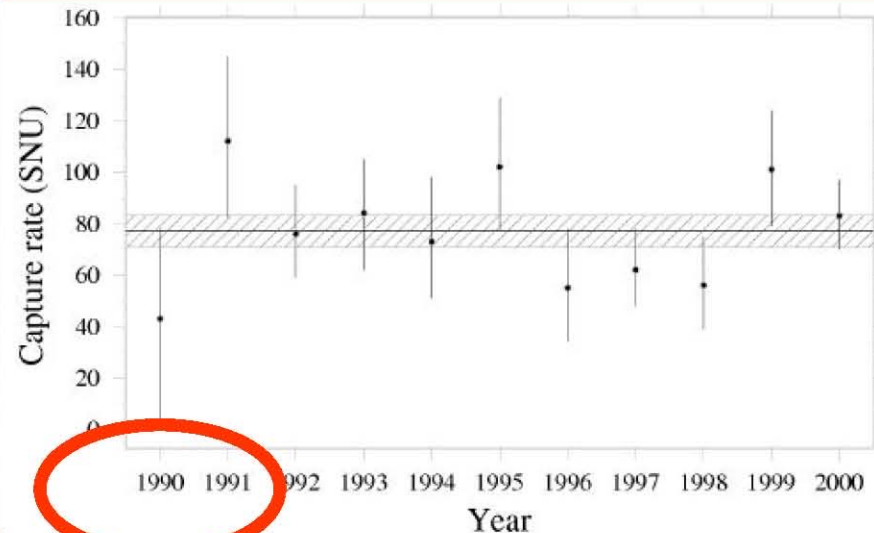
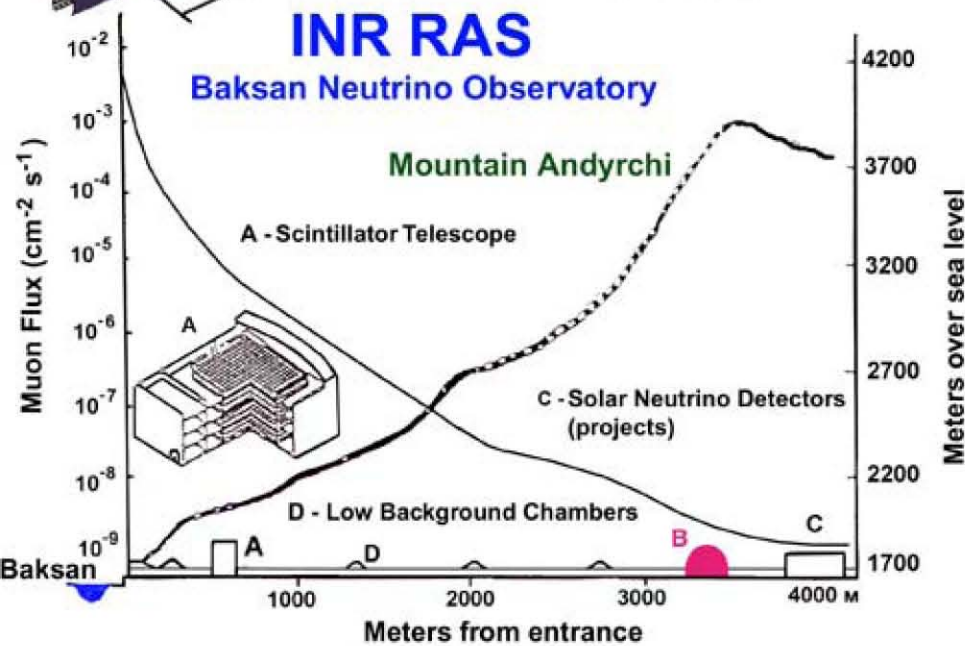

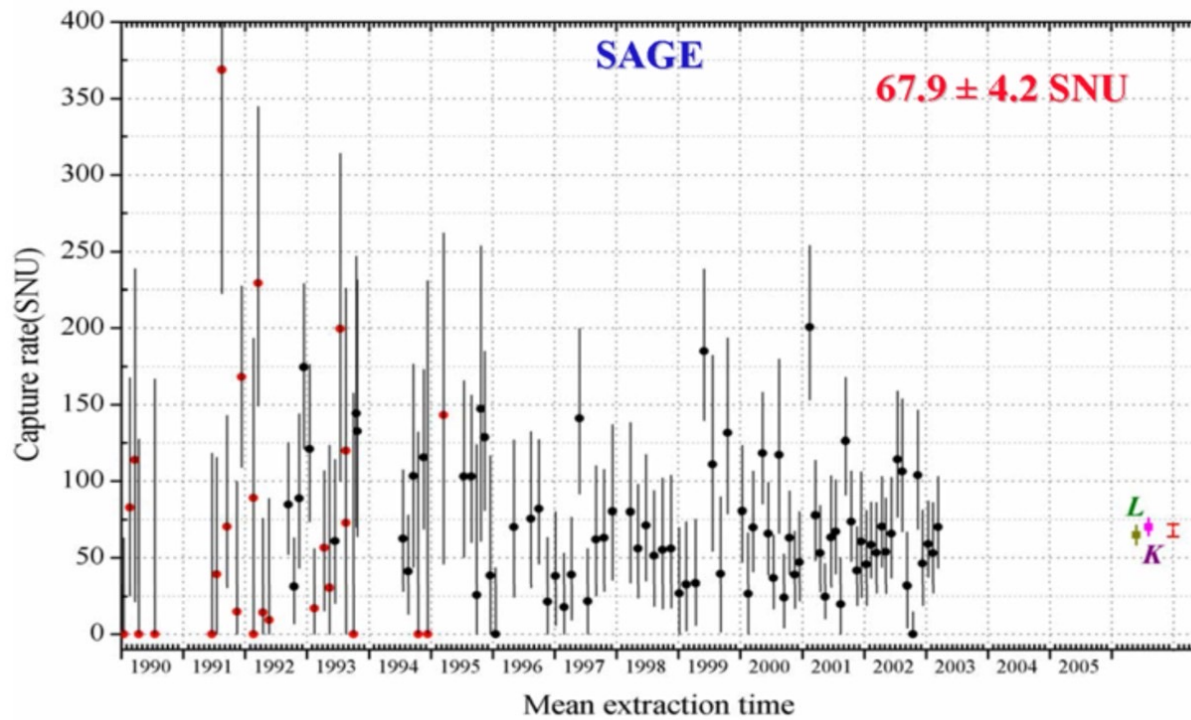
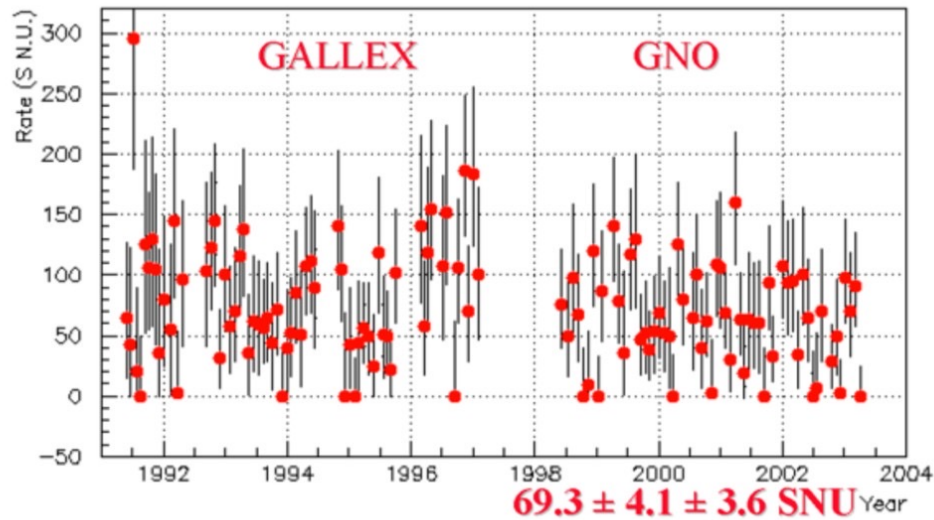

# Risultati degli esperimenti della I generazione:

## The solar neutrino problem

	SAGE + GALLEX	Chlorine	Kamiokande
Target Material	$^{71}\text{Ga}$	$^{37}\text{Cl}$	$\text{H}_2\text{O}$
Reaction	$\nu_e + ^{71}\text{Ga} \rightarrow ^{71}\text{Ge} + e^-$	$\nu_e + ^{37}\text{Cl} \rightarrow ^{37}\text{Ar} + e^-$	$\nu + e^- \rightarrow \nu + e^-$
Detection Method	Radiochemical	Radiochemical	Cerenkov
Detection Threshold	0.234 MeV	0.814 MeV	7.0 MeV
Neutrinos Detected	All	$^7\text{Be}$ and $^8\text{B}$	$^8\text{B}$
Predicted Rate	$132 \pm 7 \text{ SNU}^*$	$9 \pm 1 \text{ SNU}$	$5.7 \pm 0.8 \text{ flux units}^{**}$
Observed Rate	$74 \pm 8 \text{ SNU}$	$2.5 \pm 0.2 \text{ SNU}$	$2.9 \pm 0.4 \text{ flux units}$

\*1 SNU =  $10^{-36}$  captures per target atom per second.  
 \*\*In units of  $10^6$  neutrinos per square centimeter per second.

Total Rates: Standard Model vs. Experiment  
 Bahcall-Pinsonneault 2000

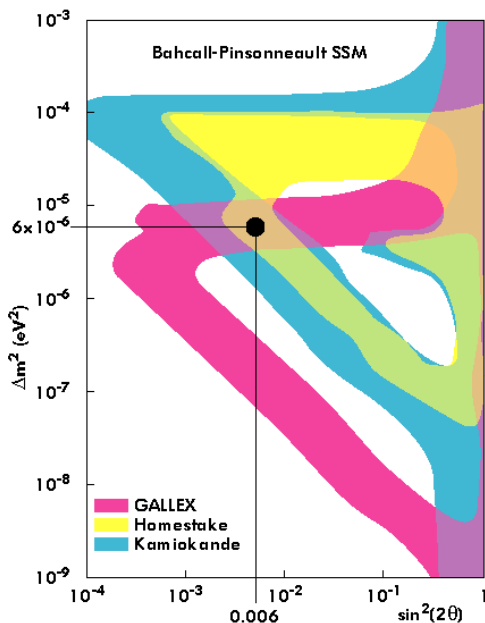
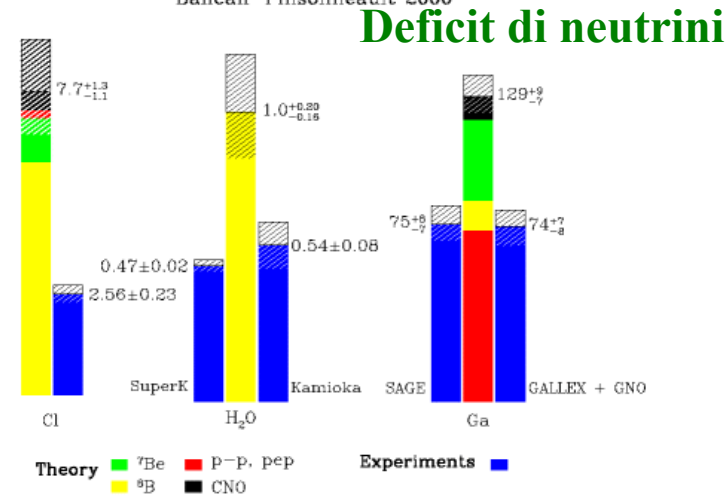

### Possibili soluzioni

- Nuovi modelli solari
- $\nu$  ( $^7\text{Be}$ ) assente
- $\nu$  vacuum oscillation ( $\Delta m^2 \sim 10^{-11} \text{ eV}^2$ ,  $\sin^2 2\theta \sim 0.8$ )
- momento magnetico del  $\nu$  (attività solare vs flusso)
- MSW ( $\Delta m^2 \sim 10^{-6} \text{ eV}^2$ ,  $\sin^2 2\theta \sim 0.006$ )

# Vacuum neutrino oscillations

Interaction eigenstates are linear combination of mass eigenstates

$$|\nu_e\rangle = \cos\theta |\nu_1\rangle + \sin\theta |\nu_2\rangle$$

$$|\nu_\mu\rangle = -\sin\theta |\nu_1\rangle + \cos\theta |\nu_2\rangle$$

An electron neutrino evolves in time into the state

$$|\nu_e(t)\rangle = \cos\theta e^{iE_1 t} |\nu_1\rangle + e^{iE_2 t} \sin\theta |\nu_2\rangle$$

Probability amplitude for e-nu to mu-nu conversion

$$A(\nu_e \rightarrow \nu_\mu) = \langle \nu_\mu | \nu_e(t) \rangle$$

Probability of nu-e to convert into nu-mu

$$P(\nu_e \rightarrow \nu_\mu) = |A(\nu_e \rightarrow \nu_\mu)|^2$$

When neutrinos are relativistic

$$(E_2 - E_1) = \sqrt{(p^2 + m_2^2)} - \sqrt{(p^2 + m_1^2)} = \frac{\Delta m^2}{2p}$$

Neutrinos can change flavour during propagation with a probability

$$P(\nu_e \rightarrow \nu_\mu) = \sin^2(2\theta) \sin^2\left(\frac{\Delta m^2 L}{4E}\right) = \sin^2(2\theta) \sin^2\left(1.27 \frac{\Delta m^2 L}{E}\right)$$

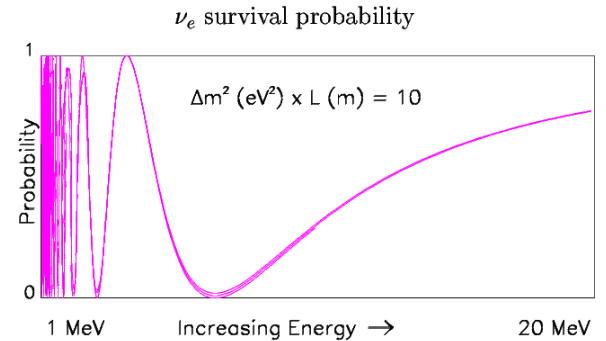
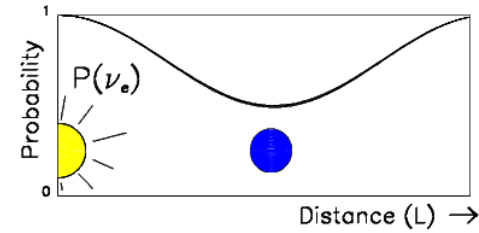

$$= -\sin\theta \cos\theta e^{iE_1 t} + \cos\theta \sin\theta e^{iE_2 t}$$

$$= \sin 2\theta \frac{e^{iE_2 t} - e^{iE_1 t}}{2}$$

$\Delta m^2$  in  $\text{eV}^2$ ; L in km; E in GeV

$L = 1.5 \times 10^{11}$  m

# Oscillation Interpretations

- “Just-So” or Vacuum Oscillations

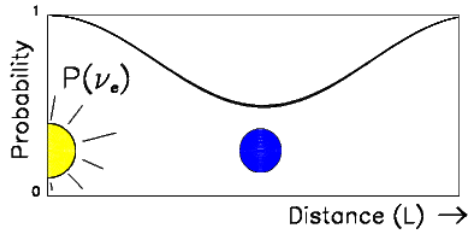

- Try to fit the results into the the oscillation formula

$$P_{osc} = \sin^2 2\theta \sin^2 (1.27 \Delta m^2 L/E)$$

for  $L \approx 10^{11}(\text{m})$

$\nu_e$  survival probability

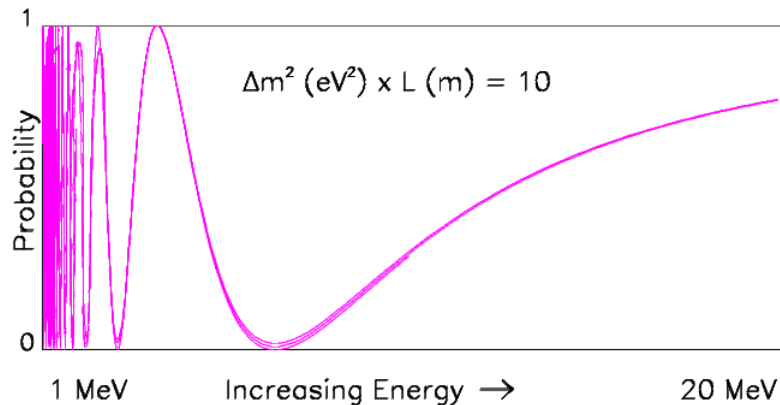

- MSW or Matter Effects in Sun (Mikheyev-Smirnov-Wolfenstein)

- Mass eigenstates propagate
- But these are mixtures of flavor eigenstates

- They have different interactions with  $e$ 's in sun

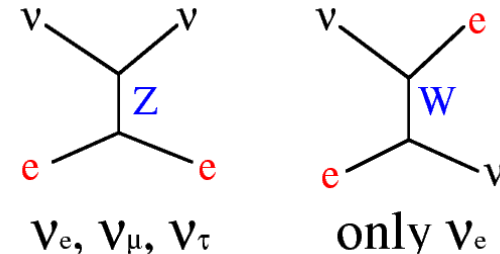

- If  $N$  = electron density then

$$\text{Prob}(\nu_e \rightarrow \nu_\mu) = (\sin^2 2\theta/W^2) \sin^2 (1.27W\Delta m^2 L/E)$$

where  $W^2 = \sin^2 2\theta + (\sqrt{2}G_F N(2E/\Delta m^2) - \cos 2\theta)^2$

**Resonance Condition:**

$$\sin^2 2\theta_{eff} = 1 \text{ if } W^2 = \sin^2 2\theta$$

# Neutrino oscillations in matter

As typically the interactions we are interested in happen at energies much below the electroweak scale, we can start with the four-fermion interaction Lagrangian

$$\mathcal{L}_{4-f} = -2\sqrt{2}G_F(\bar{\nu}_{eL}\gamma^\rho\nu_{eL})(\bar{e}_L\gamma_\rho e_L) + \dots$$

Electron neutrinos have CC and NC interactions, while muon and tau neutrinos only the latter.

$$\langle \bar{e}\gamma_0 e \rangle = N_e \quad \langle \bar{e}\vec{\gamma}e \rangle = \langle \vec{v}_e \rangle \quad \langle \bar{e}\gamma_0\gamma_5 e \rangle = \left\langle \frac{\vec{\sigma}_e \cdot \vec{p}_e}{E_e} \right\rangle \quad \langle \bar{e}\vec{\gamma}\gamma_5 e \rangle = \langle \vec{\sigma}_e \rangle$$

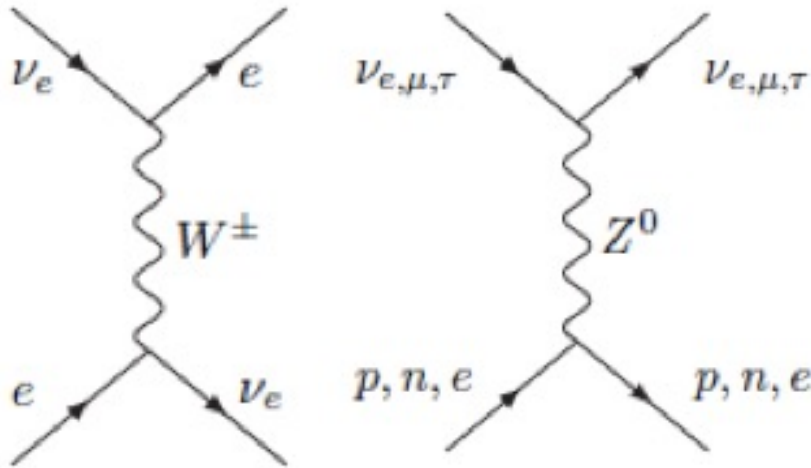

The Dirac equation (neglecting the mass for simplicity and for unpolarized electrons) is

$$\left( i\partial^\rho\gamma_\rho - \sqrt{2}G_F N_e\gamma_0 \right) |\nu_e\rangle = 0$$

For neutrinos and antineutrinos different sign!

The new term is called the matter potential.

Including both CC and NC ones has

medium	$A_{CC}$ for $\nu_e, \bar{\nu}_e$ only	$A_{NC}$ for $\nu_{e,\mu,\tau}, \bar{\nu}_{e,\mu,\tau}$
$e, \bar{e}$	$\pm\sqrt{2}G_F(N_e - N_{\bar{e}})$	$\mp\sqrt{2}G_F(N_e - N_{\bar{e}})(1 - 4s_W^2)/2$
$p, \bar{p}$	0	$\pm\sqrt{2}G_F(N_p - N_{\bar{p}})(1 - 4s_W^2)/2$
$n, \bar{n}$	0	$\mp\sqrt{2}G_F(N_n - N_{\bar{n}})/2$
ordinary matter	$\pm\sqrt{2}G_F N_e$	$\mp\sqrt{2}G_F N_n/2$

## The Hamiltonian

Let's start with the vacuum Hamiltonian for 2-neutrinos

$$i \frac{d}{dt} \begin{pmatrix} |\nu_1\rangle \\ |\nu_2\rangle \end{pmatrix} = \begin{pmatrix} E_1 & 0 \\ 0 & E_2 \end{pmatrix} \begin{pmatrix} |\nu_1\rangle \\ |\nu_2\rangle \end{pmatrix}$$

Recalling that  $|\nu_\alpha\rangle = \sum_i U_{\alpha i} |\nu_i\rangle$ , one can go into the flavour basis

$$\begin{aligned} i \frac{d}{dt} \begin{pmatrix} |\nu_\alpha\rangle \\ |\nu_\beta\rangle \end{pmatrix} &= U \begin{pmatrix} E_1 & 0 \\ 0 & E_2 \end{pmatrix} U^\dagger \begin{pmatrix} |\nu_1\rangle \\ |\nu_2\rangle \end{pmatrix} \\ &= \begin{pmatrix} -\frac{\Delta m^2}{4E} \cos 2\theta & \frac{\Delta m^2}{4E} \sin 2\theta \\ \frac{\Delta m^2}{4E} \sin 2\theta & \frac{\Delta m^2}{4E} \cos 2\theta \end{pmatrix} \begin{pmatrix} |\nu_\alpha\rangle \\ |\nu_\beta\rangle \end{pmatrix} \end{aligned}$$

The full Hamiltonian in matter can then be obtained by adding the potential terms, diagonal in the flavour basis. For electron and muon neutrinos

We have neglected common terms on the diagonal as they amount to an overall phase in the evolution.

Neutrino oscillations  
in matter

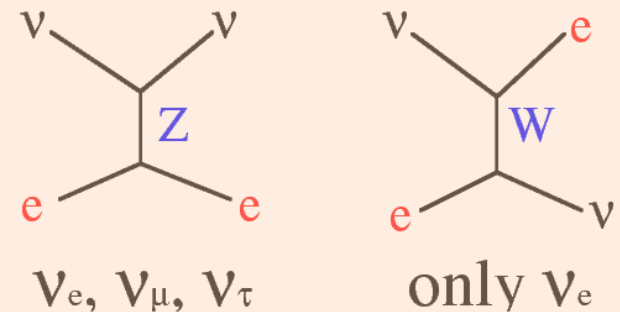

$$i \frac{d}{dt} \begin{pmatrix} |\nu_e\rangle \\ |\nu_\mu\rangle \end{pmatrix} = \begin{pmatrix} -\frac{\Delta m^2}{4E} \cos 2\theta + \sqrt{2} G_F N_e & \frac{\Delta m^2}{4E} \sin 2\theta \\ \frac{\Delta m^2}{4E} \sin 2\theta & \frac{\Delta m^2}{4E} \cos 2\theta \end{pmatrix} \begin{pmatrix} |\nu_e\rangle \\ |\nu_\mu\rangle \end{pmatrix}$$

For antineutrinos the potential has the opposite sign.

## 2-neutrino case in constant density

If the electron density is constant (a good approximation for oscillations in the Earth crust), it is easy to solve. We need to diagonalize the Hamiltonian.

- **Eigenvalues:**

$$E_A - E_B = \sqrt{\left(\frac{\Delta m^2}{2E} \cos(2\theta) - \sqrt{2}G_F N_e\right)^2 + \left(\frac{\Delta m^2}{2E} \sin(2\theta)\right)^2}$$

- The diagonal basis and the flavour basis are related by a unitary matrix with **angle in matter**

$$\tan(2\theta_m) = \frac{\frac{\Delta m^2}{2E} \sin(2\theta)}{\frac{\Delta m^2}{2E} \cos(2\theta) - \sqrt{2}G_F N_e}$$

Three interesting limits:

- If  $\sqrt{2}G_F N_e \ll \frac{\Delta m^2}{2E} \cos 2\theta$ , we recover the vacuum case and

$$\theta_m \simeq \theta$$

- If  $\sqrt{2}G_F N_e \gg \frac{\Delta m^2}{2E} \cos(2\theta)$ , matter effects dominate and oscillations are suppressed.

$$\theta_m \rightarrow \pi/2$$

- If  $\sqrt{2}G_F N_e = \frac{\Delta m^2}{2E} \cos 2\theta$ : resonance and maximal mixing

$$\theta_m = \pi/4$$

- The oscillation probability can be obtained as in the two neutrino mixing case but with

$$\begin{aligned}\theta &\rightarrow \theta_m \\ (m_2^2 - m_1^2)/(2E) &\rightarrow E_A - E_B\end{aligned}$$

$$P(\nu_e \rightarrow \nu_\mu; t) = \sin^2(2\theta_m) \sin^2 \frac{(E_A - E_B)L}{2}$$

## 2-neutrino oscillations with varying density

Let's consider the case in which  $N_e$  depends on time. This happens, e.g., if a beam of neutrinos is produced and then propagates through a medium of varying density (e.g. Sun, supernovae).

$$i \frac{d}{dt} \begin{pmatrix} |\nu_e\rangle \\ |\nu_\mu\rangle \end{pmatrix} = \begin{pmatrix} -\frac{\Delta m^2}{4E} \cos 2\theta + \sqrt{2}G_F N_e(t) & \frac{\Delta m^2}{4E} \sin 2\theta \\ \frac{\Delta m^2}{4E} \sin 2\theta & \frac{\Delta m^2}{4E} \cos 2\theta \end{pmatrix} \begin{pmatrix} |\nu_e\rangle \\ |\nu_\mu\rangle \end{pmatrix}$$

At a given instant of time  $t$ , the Hamiltonian can be diagonalized by a unitary transformation as before. We find the **instantaneous matter basis and the instantaneous values of the energy**. The expressions are exactly as before but with the **angle which depends on time,  $\theta_m(t)$** .

In general, it is very difficult to find analytical solution to this problem.

## Solar neutrinos: MSW effect

- The oscillations in matter were first discussed in L. Wolfenstein, S. P. Mikheyev, A. Yu Smirnov.
- Production in the center of the Sun: matter effects dominate at high energy, negligible at low energy.

The probability of  $\nu_e$  to be

$$\nu_A \text{ is } \cos^2 \theta_m$$

$$\nu_B \text{ is } \sin^2 \theta_m$$

If matter effects dominate,  $\sin^2 \theta_m \approx 1$

In presence of adiabaticity,

$$\nu_e \rightarrow \nu_B \rightarrow \nu_2 \rightarrow P = \sin^2 \theta$$

•  $P(\nu_e \rightarrow \nu_e) = 1 - \frac{1}{2} \sin^2(2\theta)$  (averaged vacuum oscillations), when matter effects are negligible (low energies)

•  $P(\nu_e \rightarrow \nu_e) = \sin^2 \theta$  (dominant matter effects and adiabaticity) (high energies)

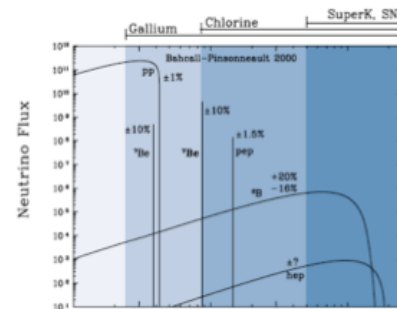

Solar neutrinos have energies which go from vacuum oscillations to adiabatic resonance.

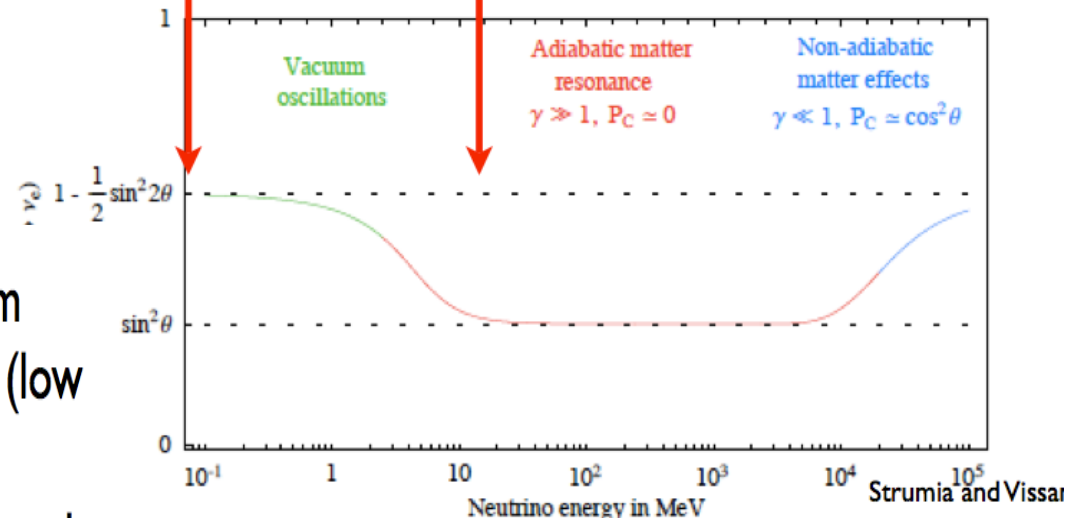

Strumia and Vissar

# Sensitivity

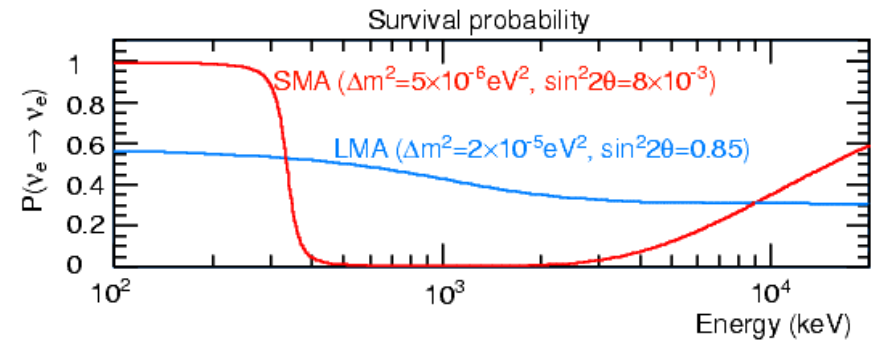
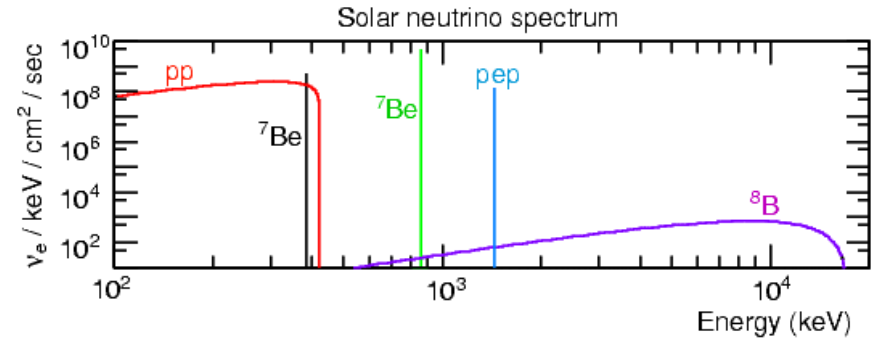
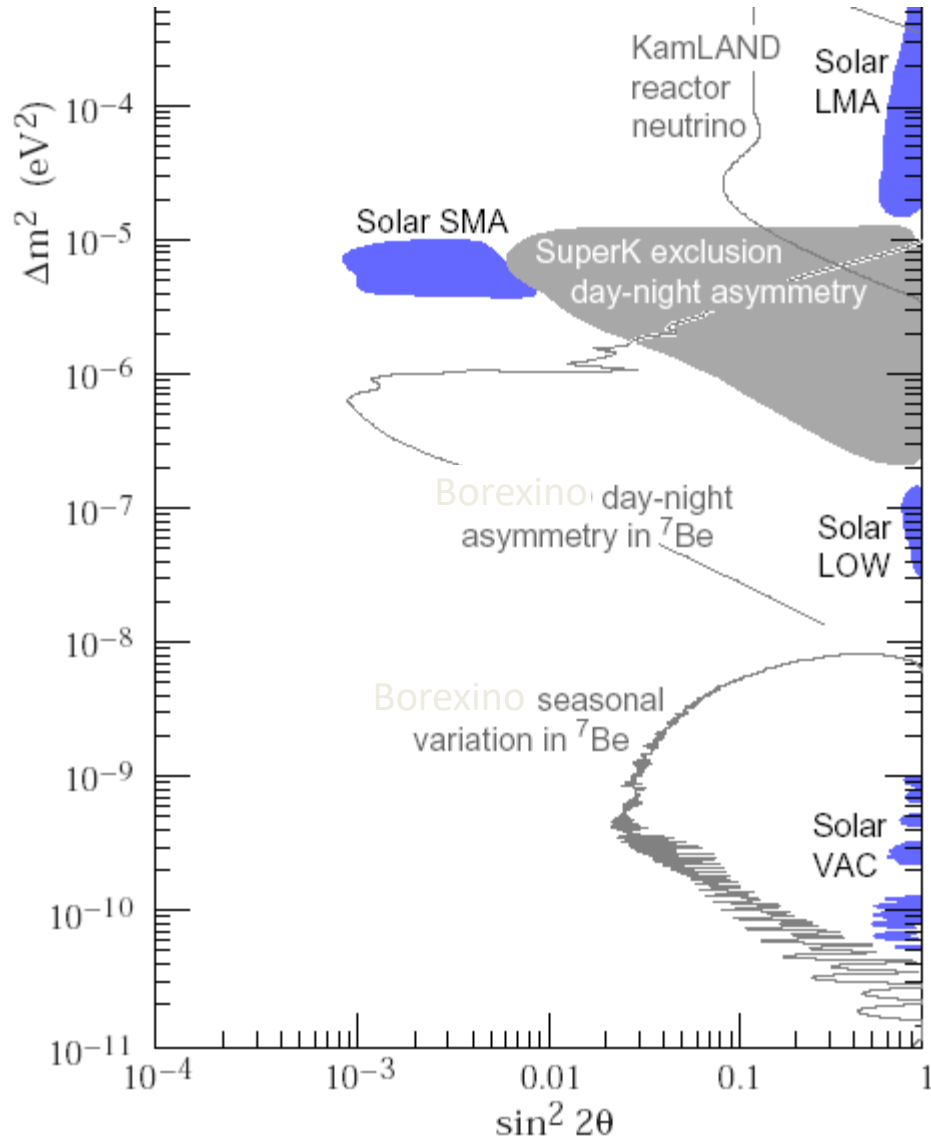

## Esperimenti della II generazione:

**Radiochimici** : **GNO**

**RealTime** : **Super-Kamiokande, SNO,  
Borexino**

# Super-K Experiment H<sub>2</sub>O Cerenkov Detectors

- SuperK

- 22.5 kton fiducial volume
- 36 m high, 34 m diam.
- 11,146 phototubes (50 cm)
- Energy threshold: 6.5 MeV
- Linac (5 - 16 MeV) for in-situ calibration

Both NC & CC scatters

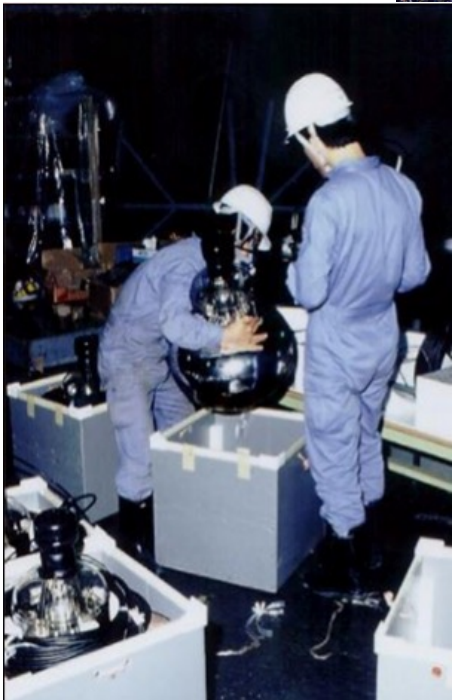
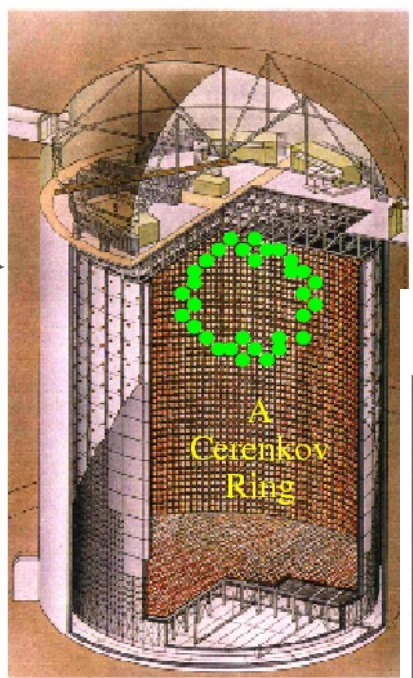
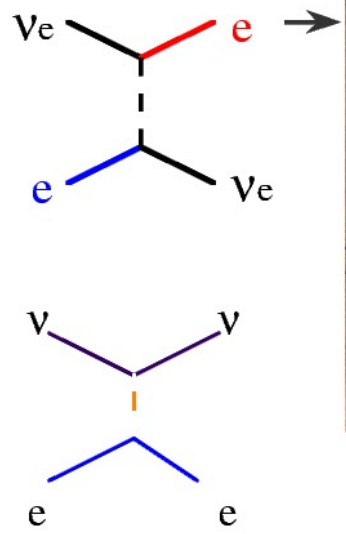

Elettrone

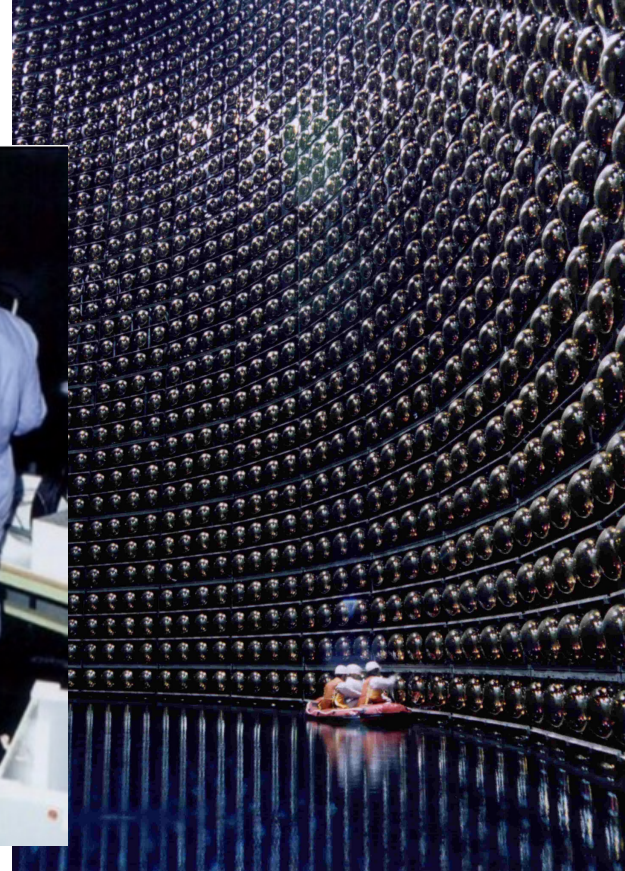
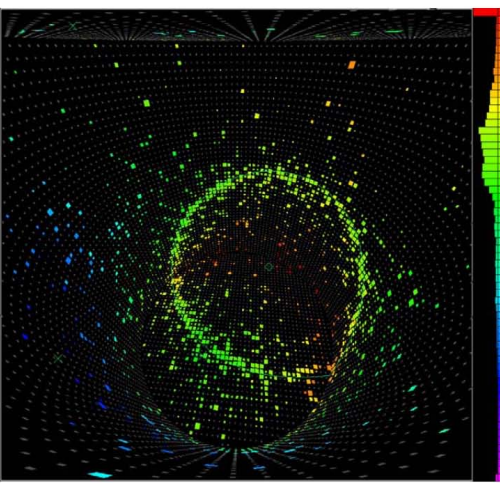

MUONE

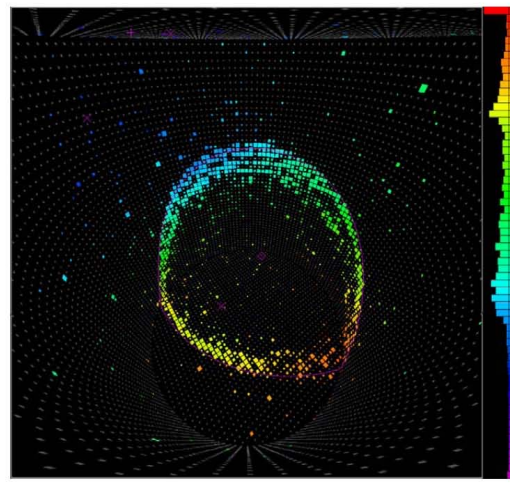

# Super-Kamiokande: Sun in the Light of Neutrinos ( $^8\text{B}$ $\nu$ , highest energy tail)

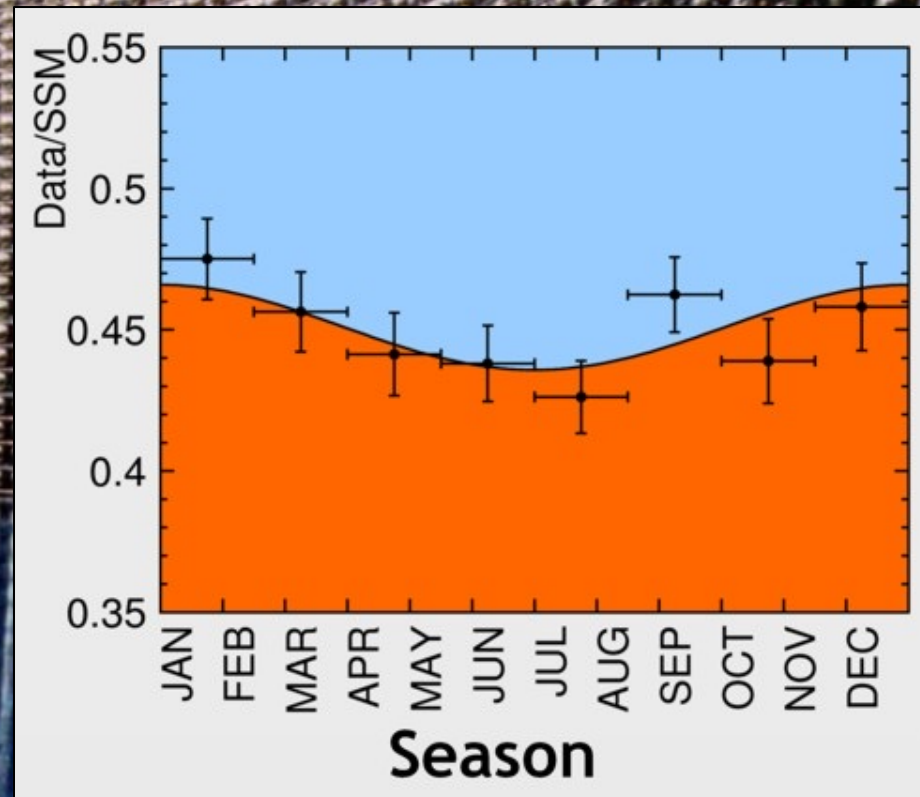
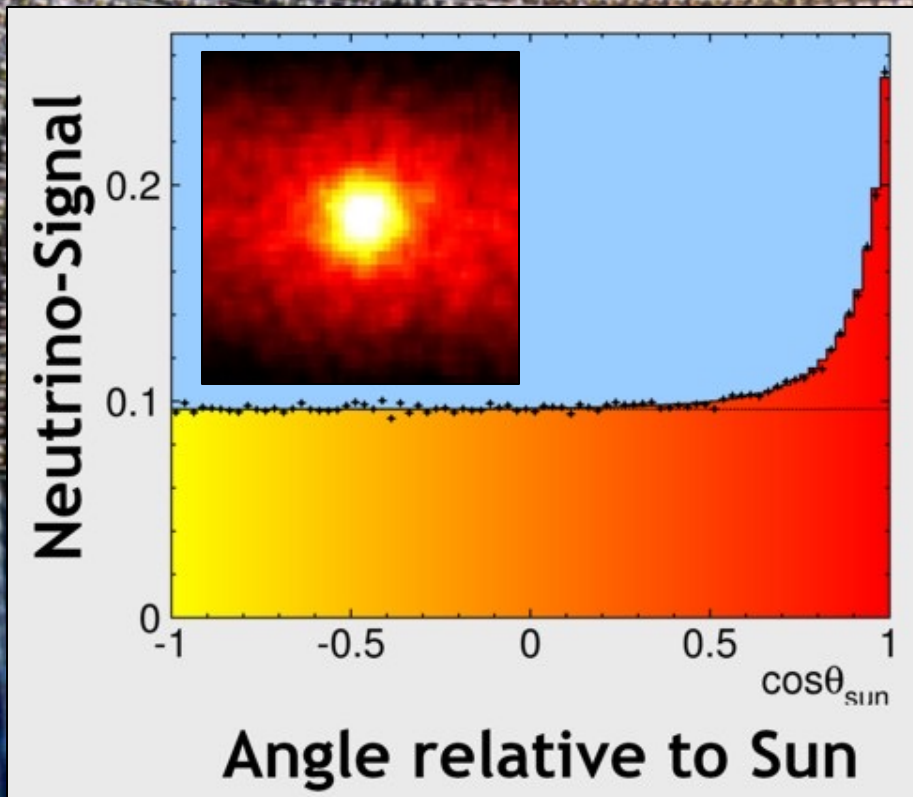

**Measured flux (1117 days)  
May '96 - April '00**

$$\Phi = 2.40 \pm 0.03(\text{stat.})_{-0.07}^{+0.08}(\text{syst.}) \times 10^6 / \text{cm}^2 / \text{s}$$

$$\text{Data/SSM} = 0.465 \pm 0.005(\text{stat.})_{-0.013}^{+0.015}(\text{syst.})$$

# Risultati dell' esperimento SK

One of the results: arXiv:1312.5176

## First Indication of Terrestrial Matter Effects on Solar Neutrino Oscillation

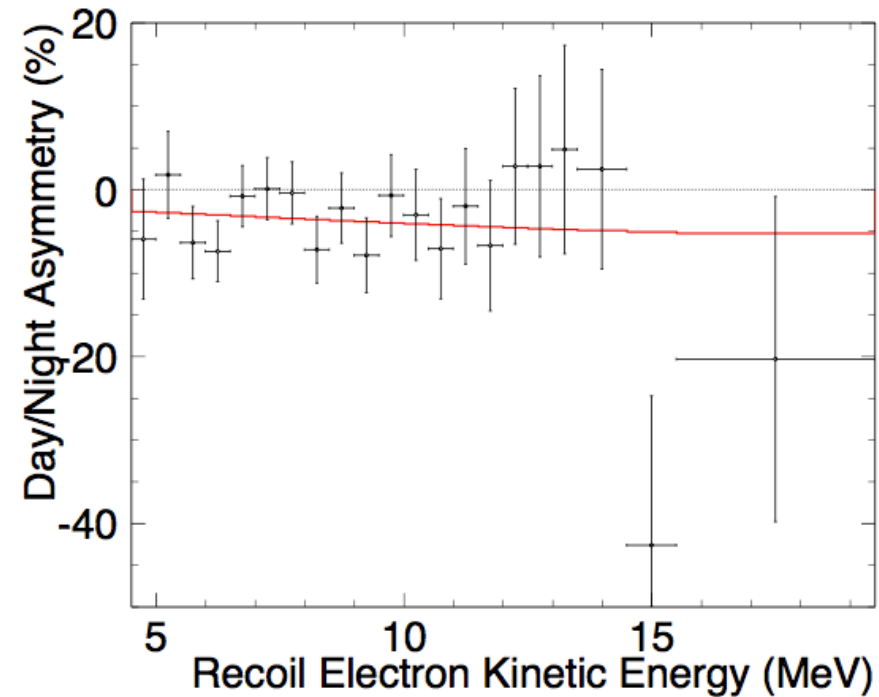
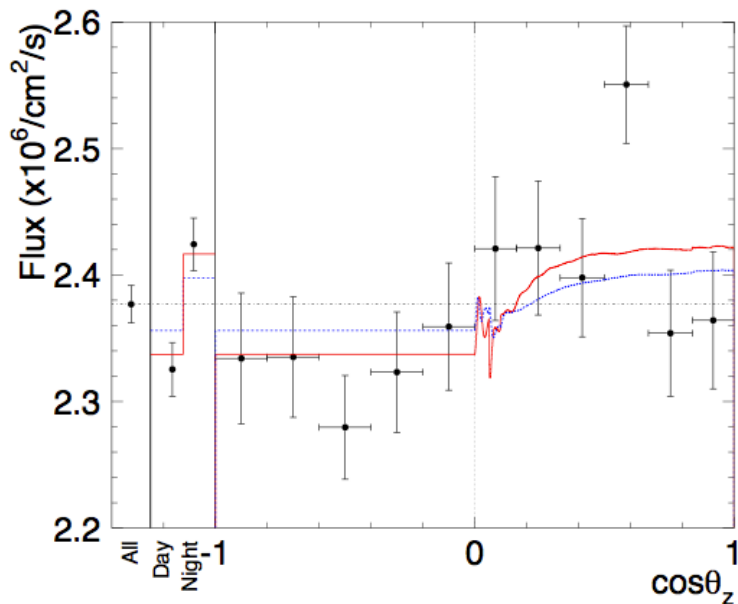

Day/Night Asymmetry ( $2.7 \sigma$  effect):

$$A_{\text{DN}}^{\text{fit}} = (-3.2 \pm 1.1(\text{stat}) \pm 0.5(\text{syst}))\%$$

# Risultati degli esperimenti della I generazione + SK

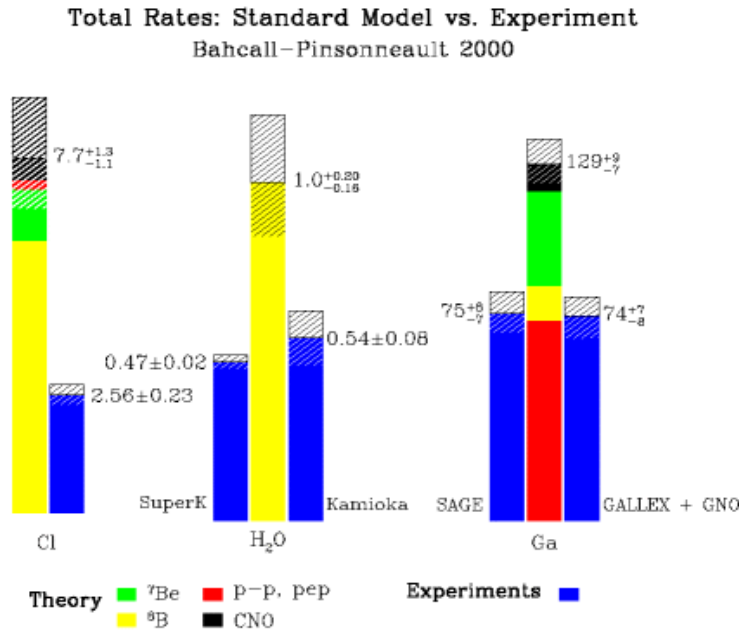

**Deficit di neutrini**

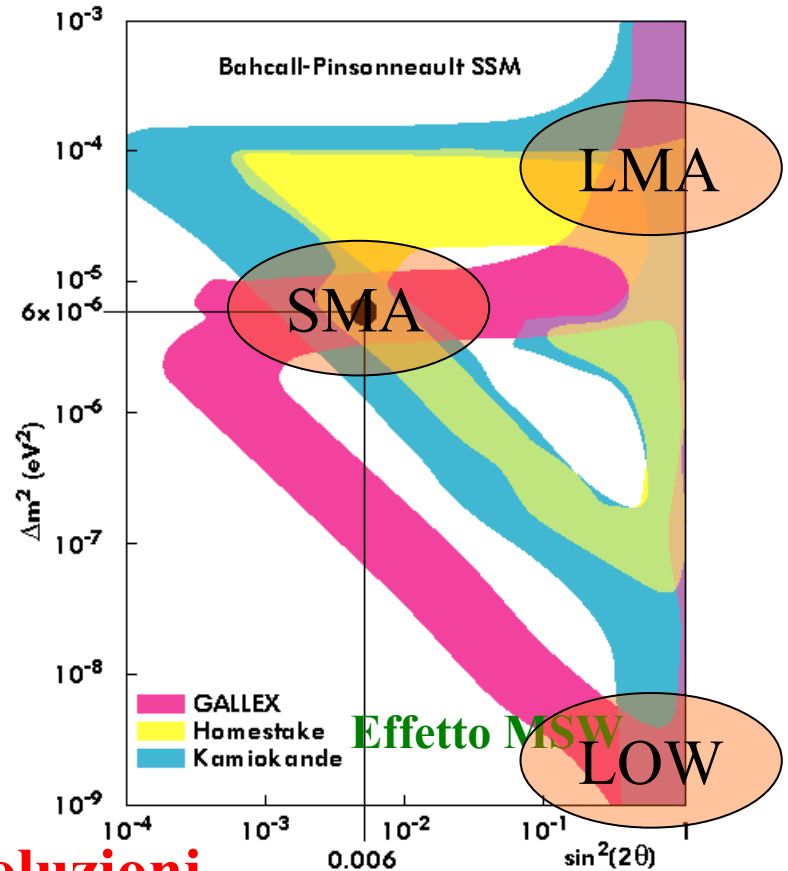

## Possibili soluzioni

- Nuovi modelli solari
- $\nu$  ( ${}^7\text{Be}$ ) assente
- $\nu$  vacuum oscillation ( $\Delta m^2 \sim 10^{-11} \text{eV}^2$ ,  $\sin^2 2\theta \sim 0.8$ )
- momento magnetico del  $\nu$  (attività solare vs flusso)
- MSW ( $\Delta m^2 \sim 10^{-6} \text{eV}^2$ ,  $\sin^2 2\theta \sim 0.006$ )

# Risultati Ga + Cl + SK

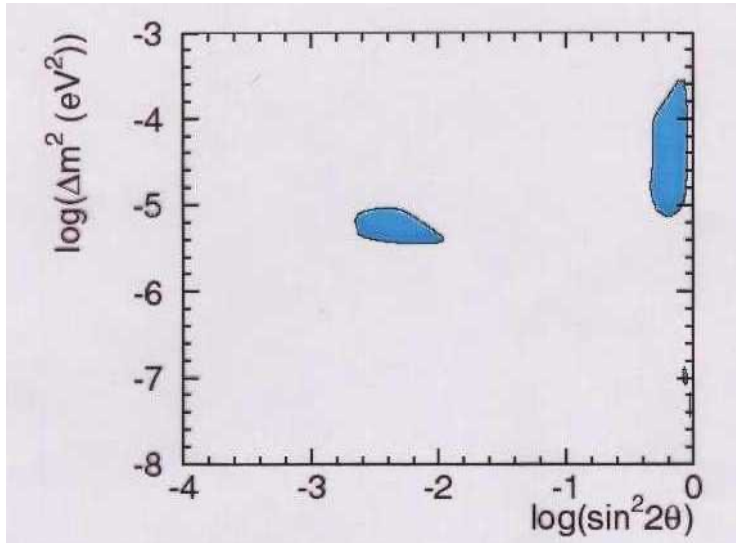

**Effetto MSW**

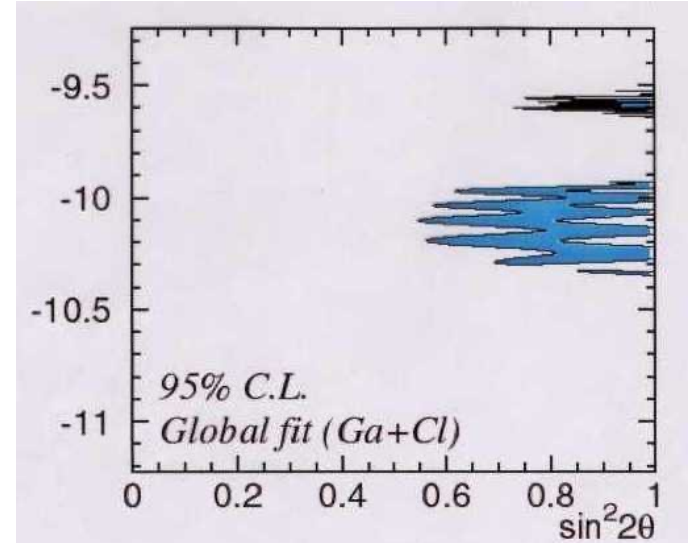

**Oscillazione nel vuoto**

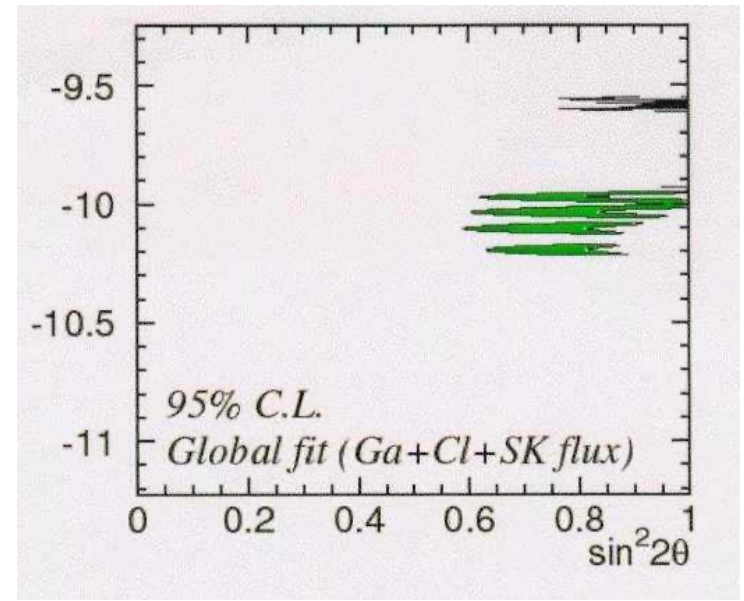
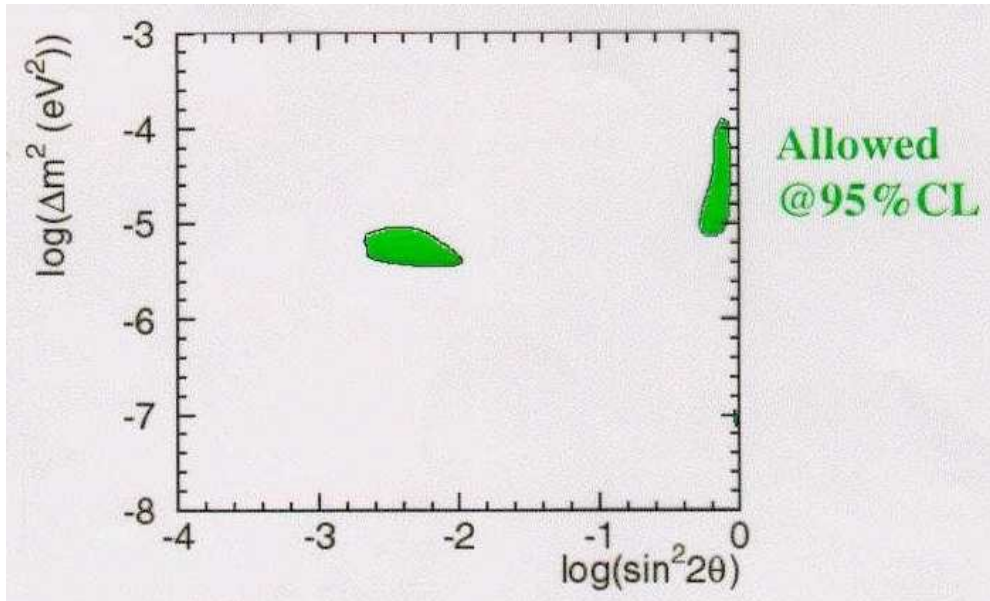

Nei primi anni 2000 due esperimenti hanno validato l'ipotesi che il deficit dei neutrini solari è dovuto ad oscillazioni e non a problemi del SSM

1. SNO il flusso di  $\nu_e$  emessi dal sole arriva sulla terra non solo come  $\nu_e$ , rivelati dagli esperimenti precedenti, ma anche come  $\nu_\mu$   $\nu_\tau$
1. KAMLAND gli anti- $\nu_e$  emessi da reattori nucleari mostrano un deficit corrispondente a quello osservato nei neutrini solari (ipotesi CPT)

# Sudbury Neutrino Observatory (SNO)

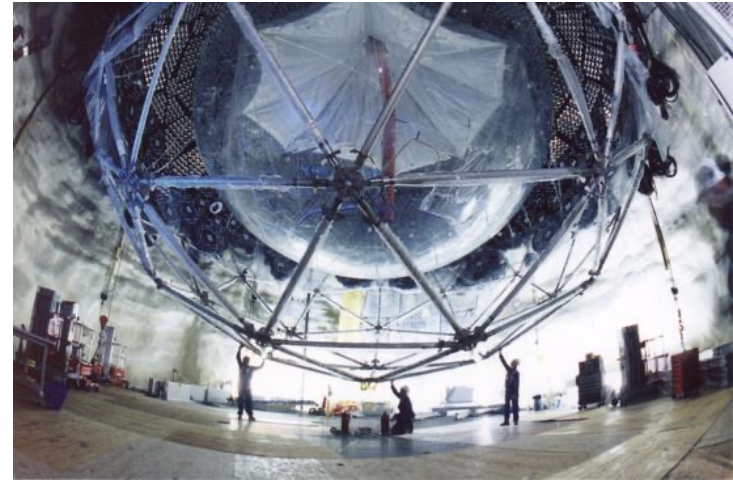
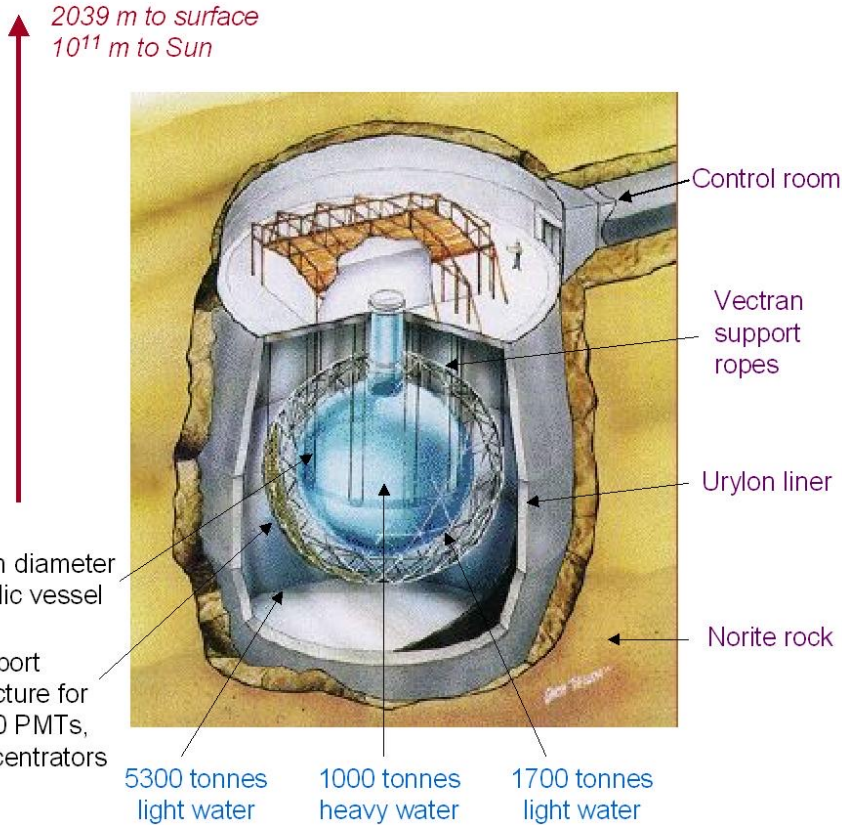

- **Location:** 6800 ft. level of INCO's Creighton mine near Sudbury, ON, Canada (~70 muons / day)
- **SNO Detector:** 9438<sub>inward</sub> + 91<sub>outward</sub> Hamamatsu 8" PMTs + concentrators = 64% coverage



**1000 tons D<sub>2</sub>O  
(12m Inner Vessel)**

- **Advantages of Heavy vs Light Water**
  - $\nu_e + d \rightarrow p + p + e^-$  (D<sub>2</sub>O)
  - $\nu_e + e^- \rightarrow \nu_e + e^-$  (H<sub>2</sub>O or D<sub>2</sub>O)
  - Cross section  $\propto (E_{cm})^2 = s$ 
    - $s = 2 m_{target} E_\nu$   
 $\Rightarrow s_N/s_{e^-} = M_p/M_e \approx 2000$
  - But x5 more electrons in D<sub>2</sub>O than D' s

**SNO (1kton) 8.1 CC events/day**  
**SuperK (22ktons) 25 events/day**

# SNO Results

## $\nu$ Reactions in Heavy Water

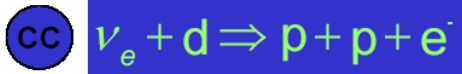

- "Charged Current"
- $\nu_e$  only.

30 events/day

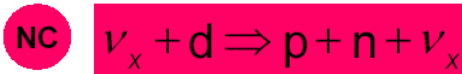

- "Neutral Current"
- Equal cross section for all active  $\nu$  types

$E_{thr} = 2.225 \text{ MeV}$

- $n + d \rightarrow t + \gamma (6.26 \text{ MeV})$
  - $n + {}^{35}\text{Cl} \rightarrow {}^{36}\text{Cl} + \gamma (8.5 \text{ MeV})$
  - $n + {}^3\text{He} \rightarrow t + p$
- 3-9 events/day (for  $E_{th}=5 \text{ MeV}$ )



- "Elastic Scattering"
- Mainly sensitive to  $\nu_e$ , some sensitivity to  $\nu_\mu$  and  $\nu_\tau$

3 events/day

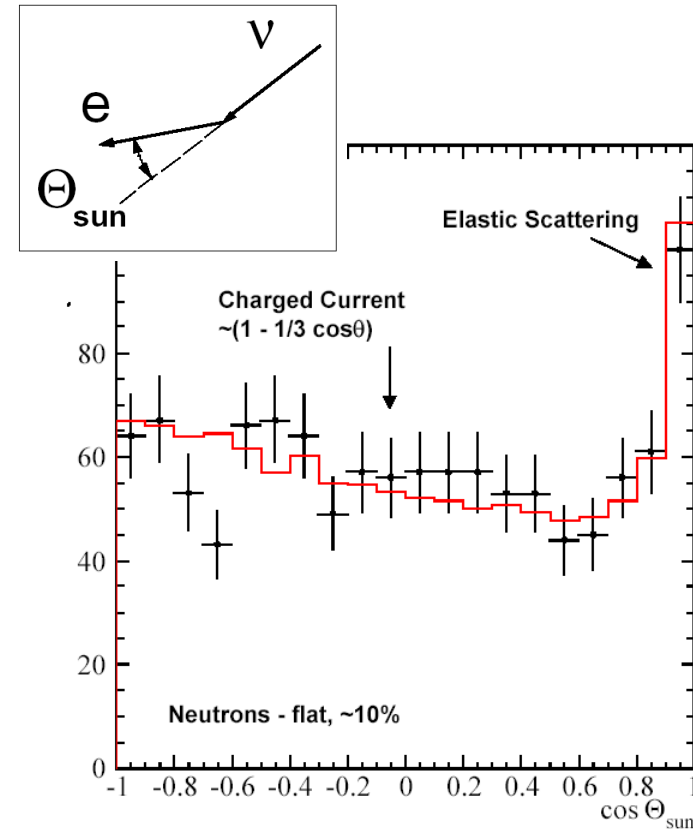

Measure total flux of solar neutrinos vs. the pure  $\nu_e$  flux

Charged-Current to Neutral Current ratio is a direct signature for oscillations

$$\frac{CC}{NC} = \frac{\nu_e}{\nu_e + \nu_\mu + \nu_\tau}$$

**ES = Elastic Scattering**

$$\nu_e = NC + CC$$

$$\nu_\mu \text{ or } \nu_\tau = NC \text{ only}$$

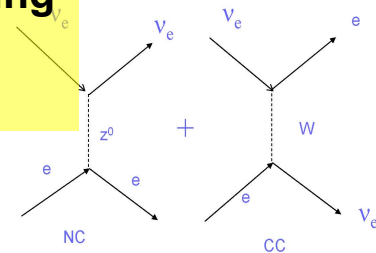

$$\sigma(CC)/\sigma(NC) = 6$$

CC/ES Could also show significant effects

$$\frac{CC}{ES} = \frac{\nu_e}{\nu_e + 0.15(\nu_\mu + \nu_\tau)}$$

# Final SNO Measurement of Boron-8 Flux

SNO Collaboration, arXiv:0910.2984

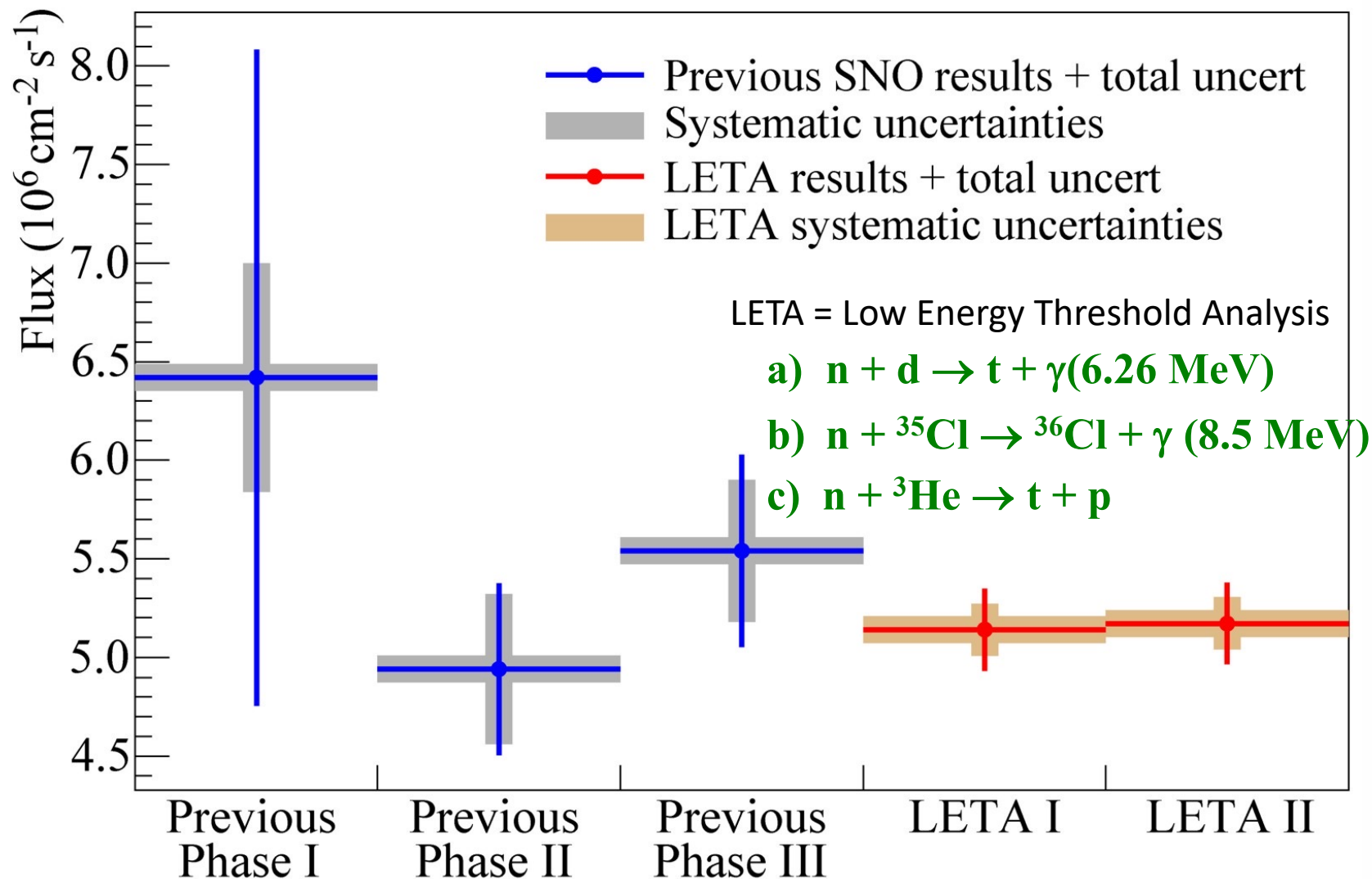

# SNO Physics

- First measurement of the total flux of  $^8\text{B}$  neutrinos:

$$\phi_{\text{total}}(^8\text{B}) = 5.44 \pm 0.99 \times 10^6 \text{ cm}^{-2} \text{ s}^{-1}$$

Agrees well with solar models:

$$\phi_{\text{SSM}}(^8\text{B}) = 5.05 \pm 0.80 \times 10^6 \text{ cm}^{-2} \text{ s}^{-1} \text{ (BPB01)}$$

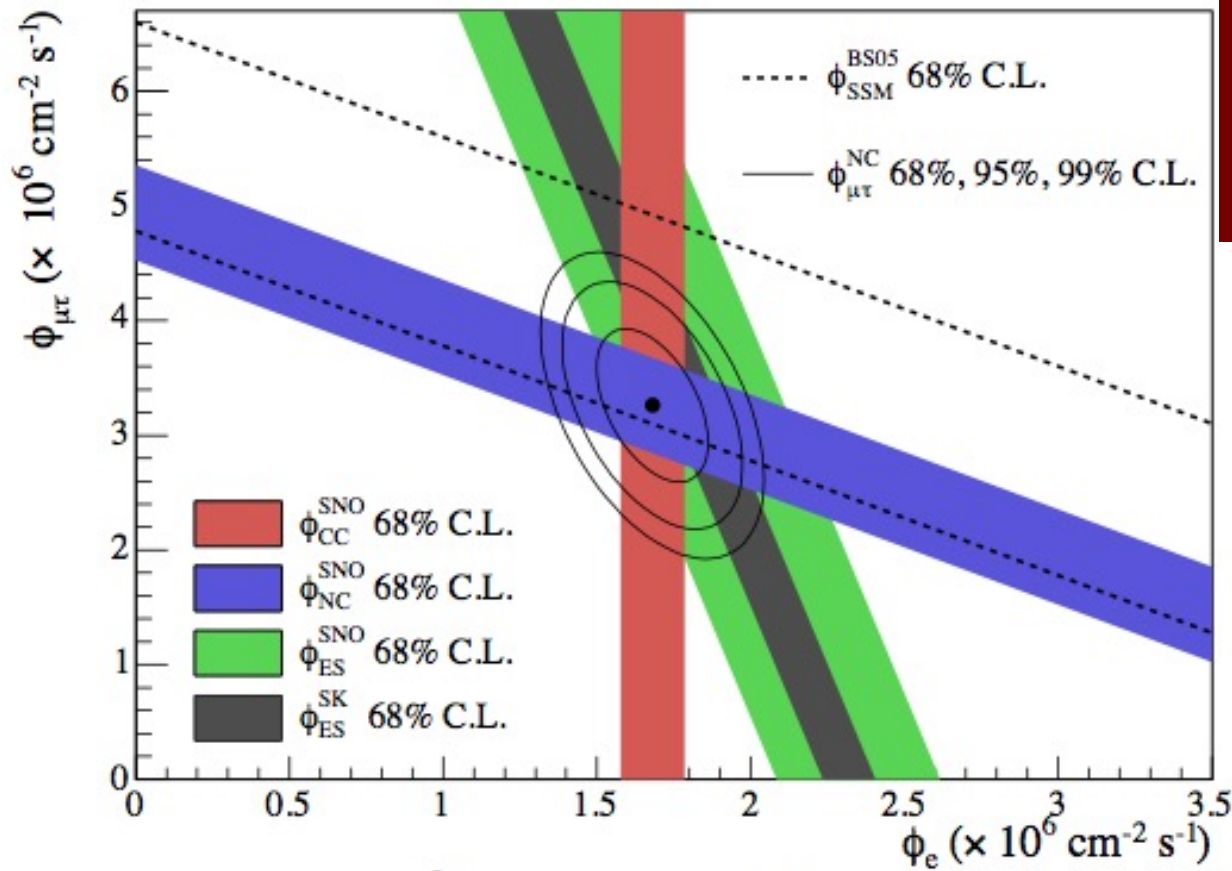

Announcement:  
June 18, 2001  
Comparison of SNO results with Super K indicates that the neutrino flux from the sun contains muon neutrinos, supporting neutrino oscillations<sup>46</sup>.

Three equations with two unknowns:

$$\phi_{CC} = \Phi_e$$

$$\phi_{NC} = \Phi_e + \Phi_{\mu,\tau}$$

$$\phi_{ES} = \Phi_e + 0.154 \Phi_{\mu,\tau}$$

$$\phi_{\text{SNO}}^{\text{CC}} = (1.68 \pm 0.06_{-0.09}^{+0.08}) \times 10^6 \text{ cm}^{-2} \text{ s}^{-1},$$

$$\phi_{\text{SNO}}^{\text{ES}} = (2.35 \pm 0.22 \pm 0.15) \times 10^6 \text{ cm}^{-2} \text{ s}^{-1},$$

$$\phi_{\text{SNO}}^{\text{NC}} = (4.94 \pm 0.21_{-0.34}^{+0.38}) \times 10^6 \text{ cm}^{-2} \text{ s}^{-1},$$

Ahmad et al. (SNO Collaboration), PRL 89:011301,2002  
(nucl-ex/0204008)

# 2015 Physics Nobel Prize for Neutrino Astronomy

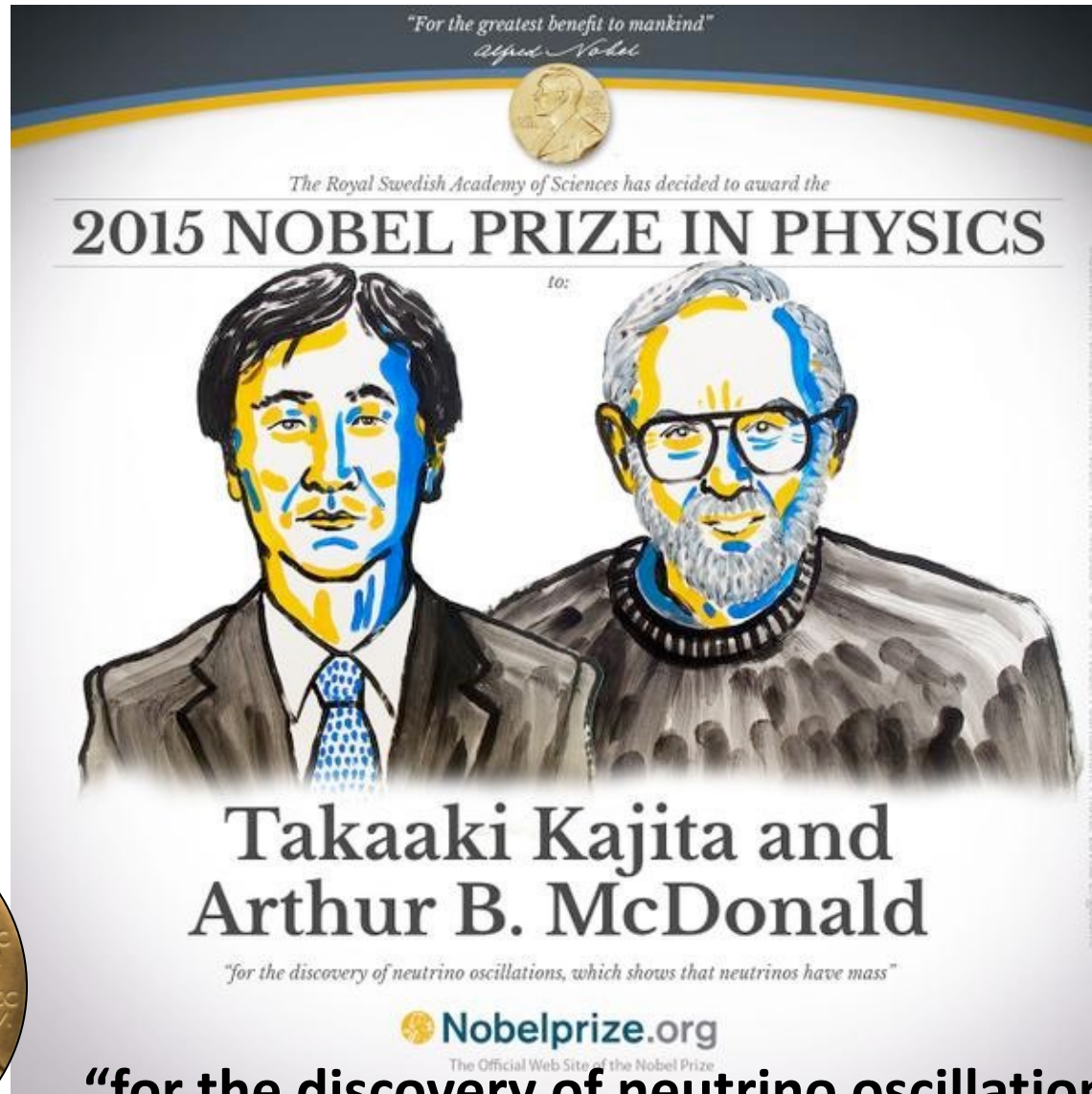

**“for the discovery of neutrino oscillations,  
which shows that neutrinos have mass”**

# Sensitivity

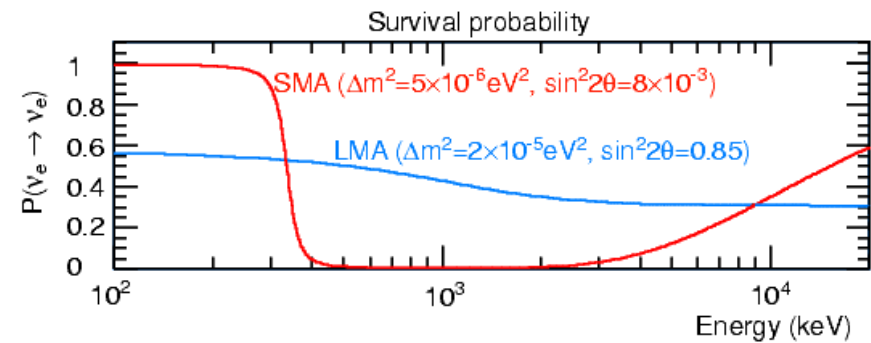
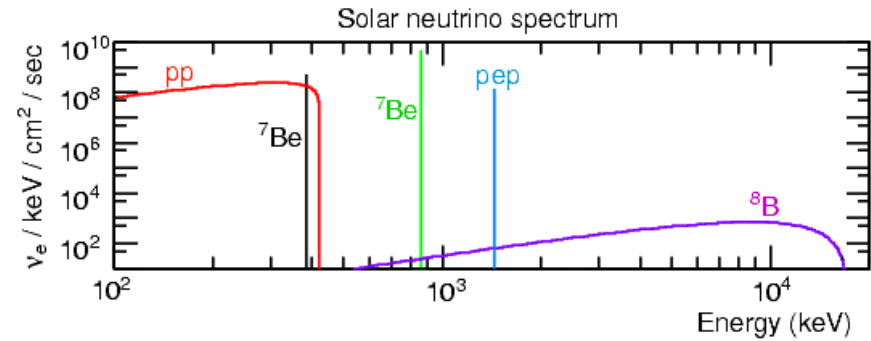
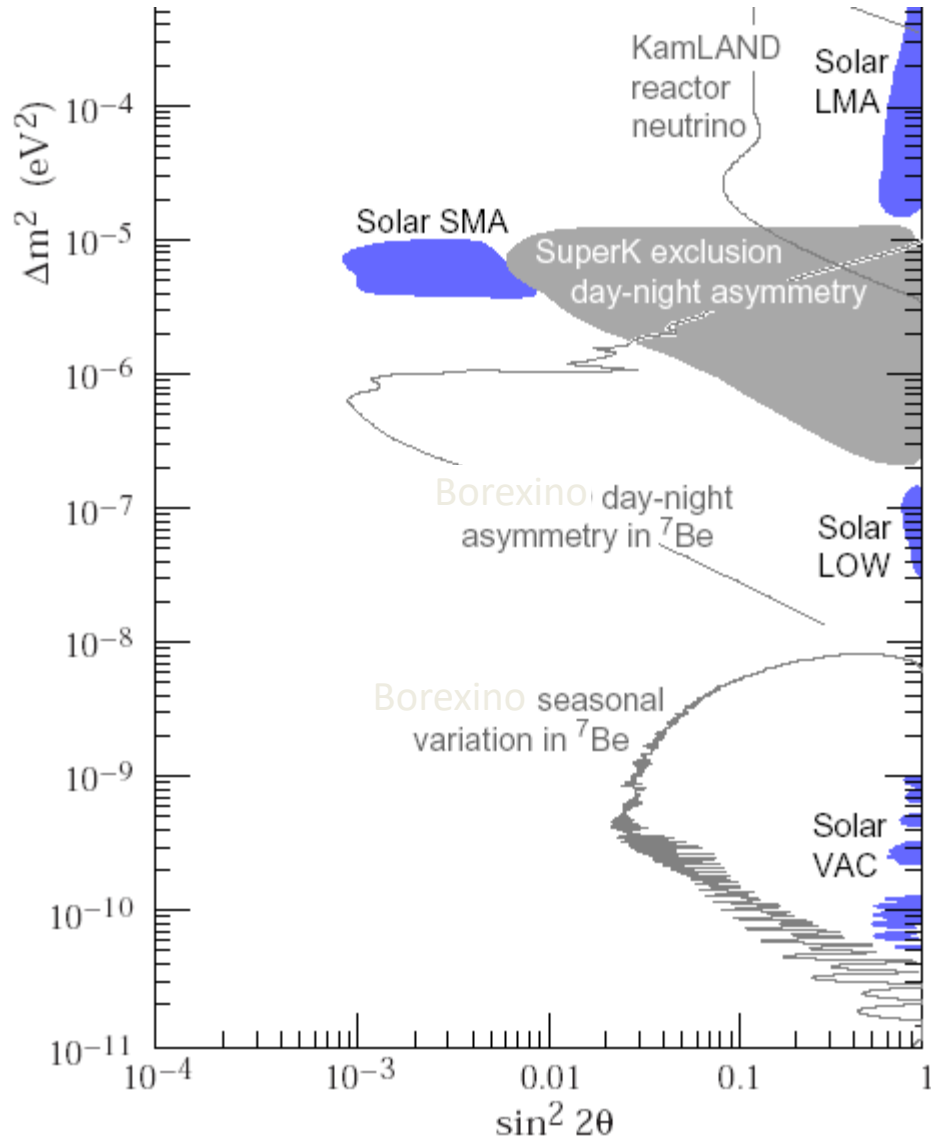

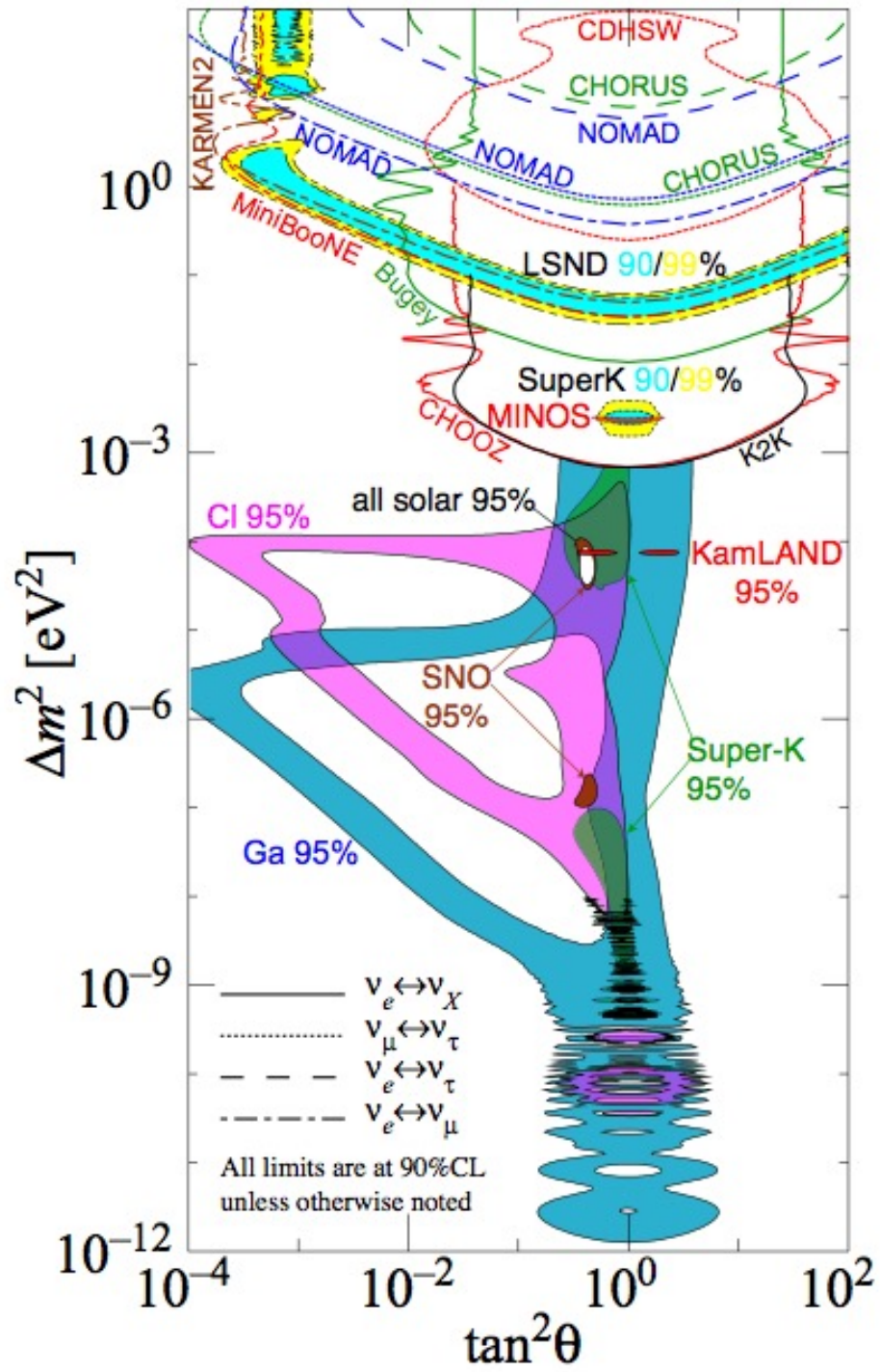

# BOREXINO

- Reaction :  $\nu_e + e^- \rightarrow \nu_e + e^-$
- Exp. site : Laboratori del Gran Sasso (3300 m.w.e.)
- Target : 300 tons (fid.:100 tons) liquid scintillator  
Pseudocumene + PPO, sphere radius 18 m
- Goals :  ${}^7\text{Be}$  neutrinos and neutrino spectroscopy.  
time behaviour; geo-neutrinos  $\bar{\nu}$

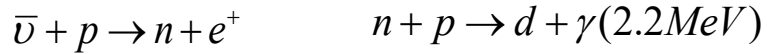
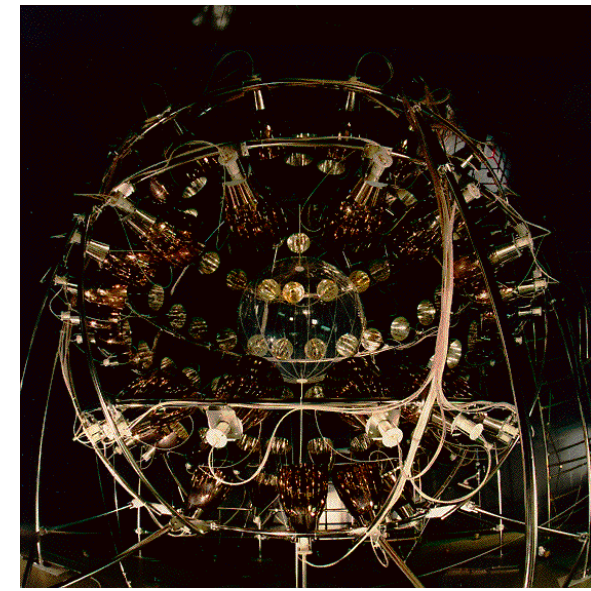

## Borexino Detector

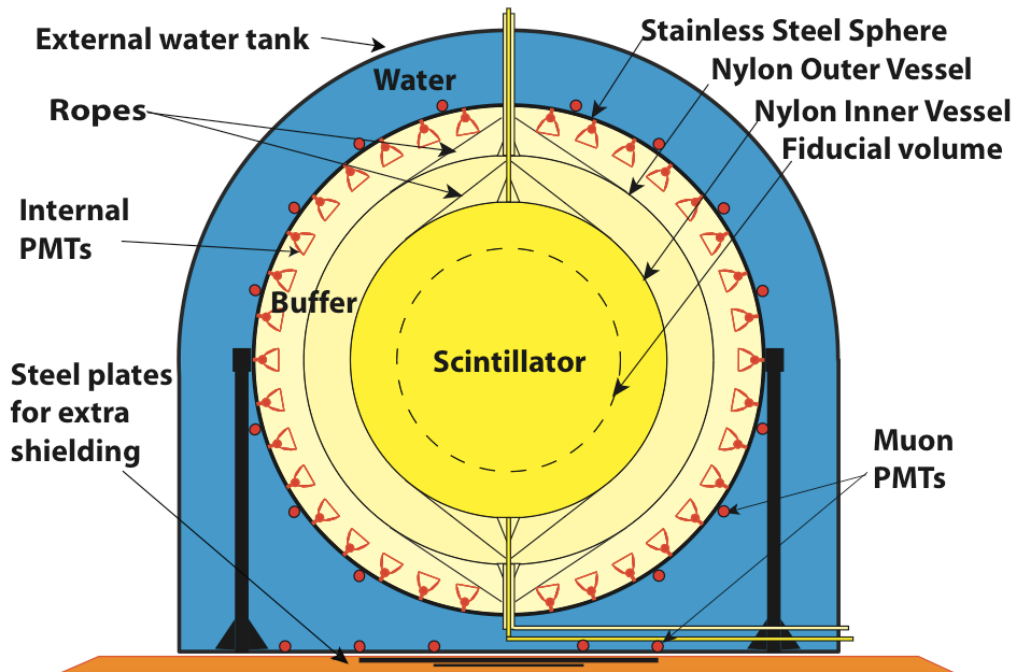

- Borexino
  - Go after  ${}^7\text{Be}$   $\nu$ 's
    - 300 ton liquid scintillator
    - 2200 8-inch phototubes
    - $E_e > 250$  keV
- Detect  $\nu_e + e^- \rightarrow \nu_e + e^-$ 
  - 55 events/day for SSM

# Background to $\nu_e$ detection

- No event-by-event signature
- Any process which produces an electron is a source of background
  - ✓ Natural radioactivity from intrinsic impurities ( $^{238}\text{U}$ ,  $^{232}\text{Th}$ ,  $^{210}\text{Pb}$ ,  $^{40}\text{K}$  ...)



The reduction of background events is a key issue

# Data reduction

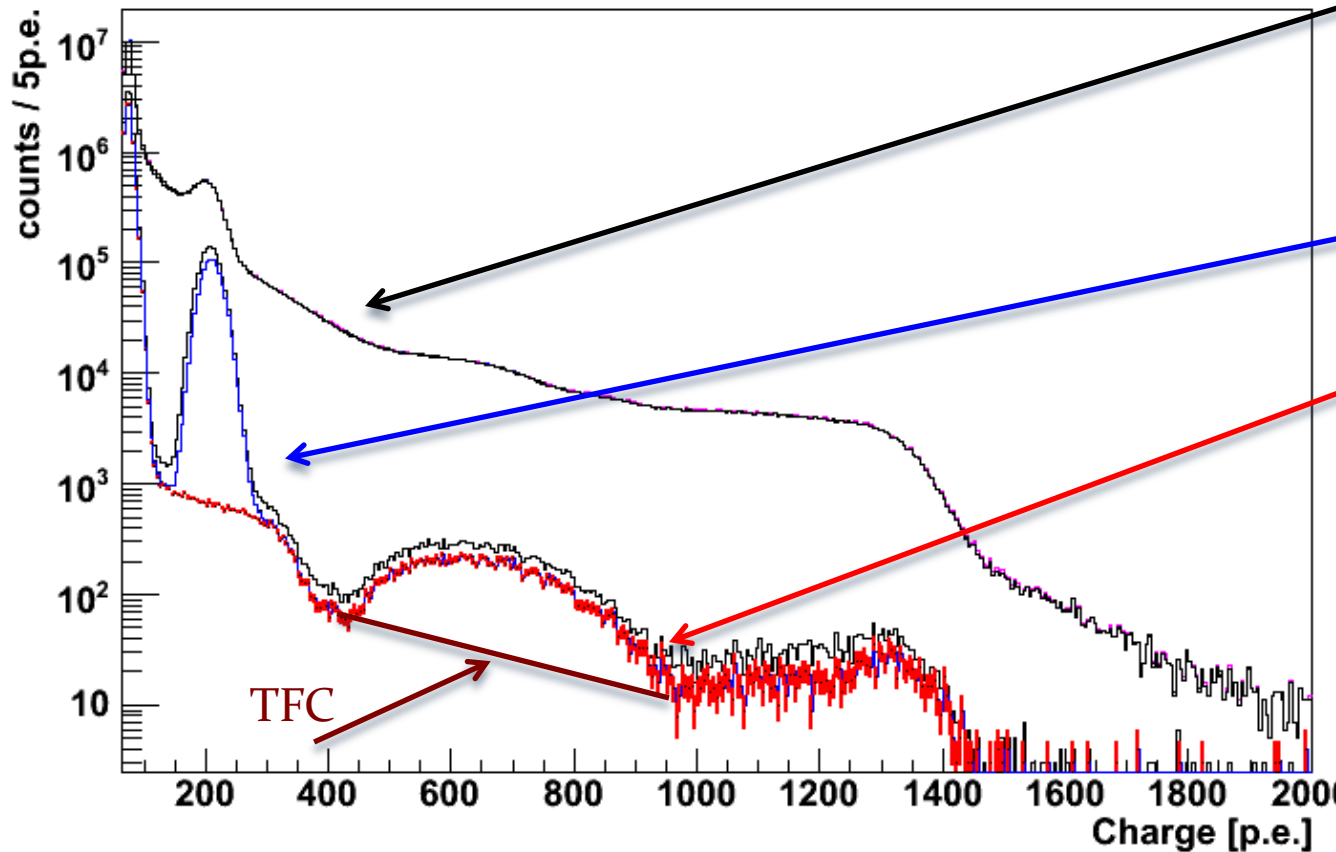

No muons +  
no 2ms correlated  
events

FV (<3m)

FV(|z|<1.7m)

Pulse shape

Detector threshold  
is 25 p.e.

Total detector  
counting  
rate above threshold  
is 30 Hz

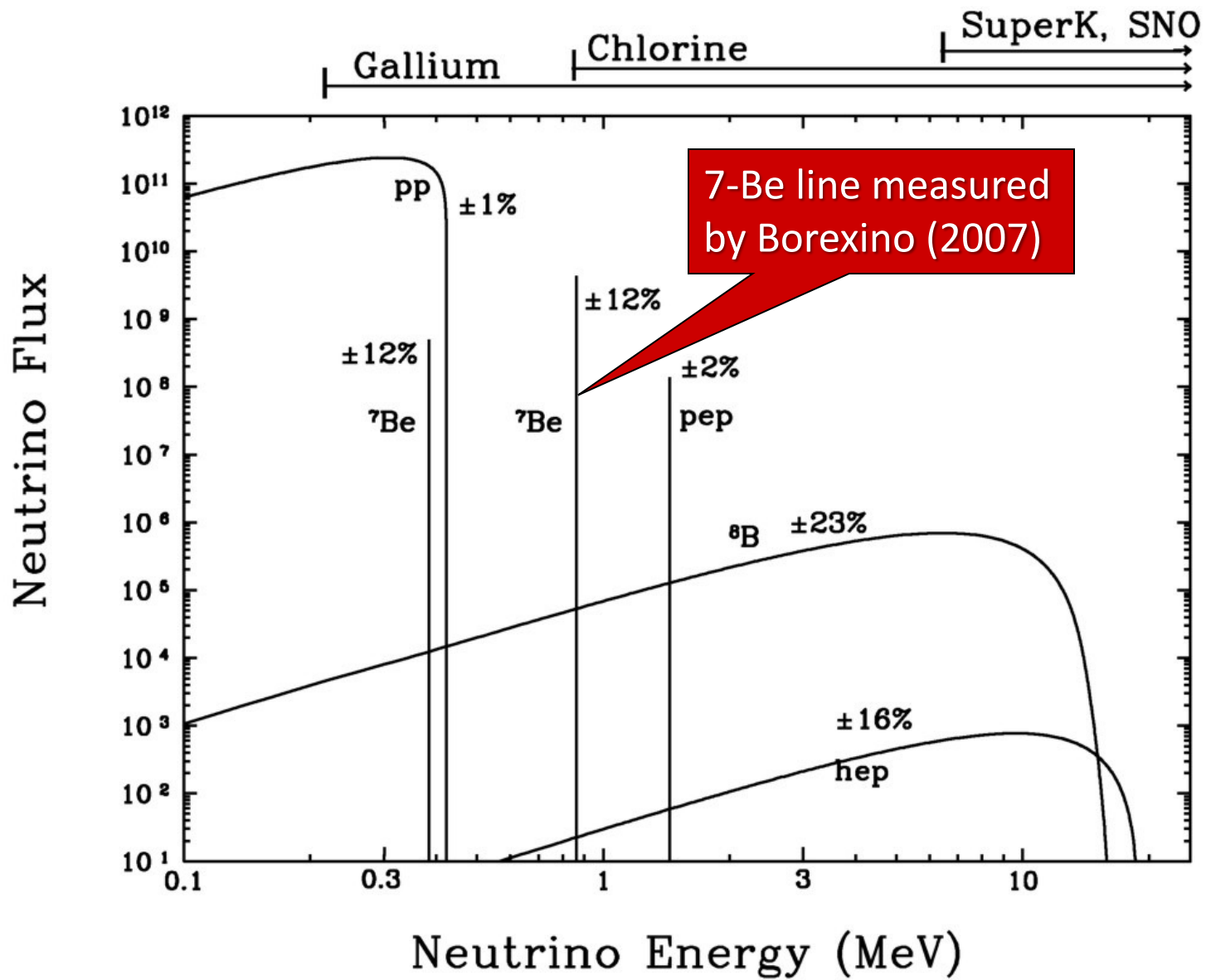

# A Compton-like interaction

$$\nu_e + e^- \rightarrow \nu_e + e^-$$

$$k + p \Rightarrow k' + p'$$

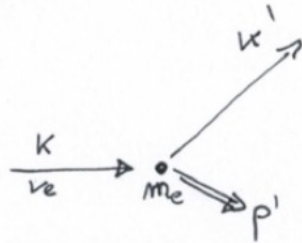

$$k - k' + p = p'$$

$$\begin{aligned} k^2 = k'^2 = 0 \\ p^2 = p'^2 = m_e^2 \end{aligned} \quad p_e = (m_e, \vec{0})$$

$$(k - k')^2 + m_e^2 + 2p(k - k') = m_e^2$$

$$k = (E_\nu, \vec{k})$$

$$k' = (E'_\nu, \vec{k}')$$

$$-2kk' + 2m_e(E_\nu - E'_\nu) = 0$$

$$2m_e(E_\nu - E'_\nu) = 2E_\nu E'_\nu (1 - \cos\theta)$$

$$\frac{1}{E'_\nu} - \frac{1}{E_\nu} = \frac{1 - \cos\theta}{m_e}$$

$$E'_\nu = \frac{E_\nu}{1 + \frac{E_\nu}{m_e}(1 - \cos\theta)}$$

$$\frac{E_\nu}{1 + \frac{2E_\nu}{m_e}} \leq E'_\nu \leq E_\nu$$

$$E_e = E_\nu - E'_\nu = E_\nu \frac{\frac{E_\nu}{m_e}(1 - \cos\theta)}{1 + \frac{E_\nu}{m_e}(1 - \cos\theta)}$$

$$0 \leq E_e \leq E_\nu \frac{1}{1 + \frac{m_e}{2E_\nu}}$$

For example, for the  ${}^7\text{Be}$  line  $E_\nu = 0.862 \text{ MeV}$

$$0 \leq E'_e \leq 0.665 \text{ MeV}$$

But, don't forget the energy resolution!!

# $^7\text{Be}$ solar $\nu_e$ measurement

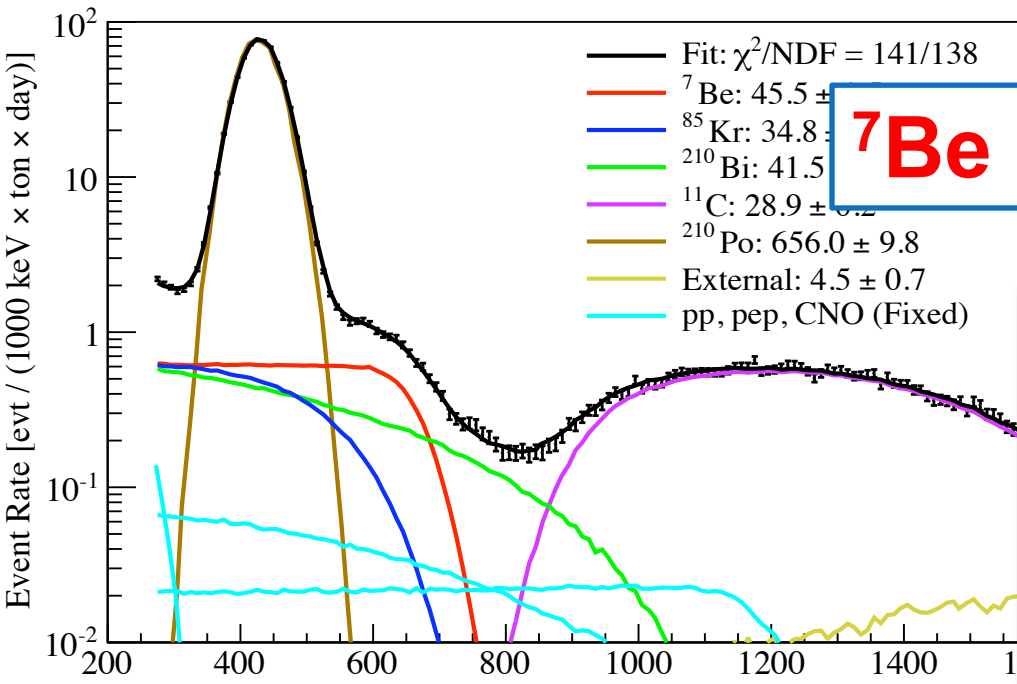

PRL 107, 141302 (2011)

Exposure: 740.7 livedays; 153.6 ton × yr

$46 \pm 1.5(\text{stat})^{+1.5}_{-1.6}(\text{syst})$  cpd/100t

$\phi_{\text{Be}} = (3.10 \pm 0.15) \times 10^9 \text{ cm}^{-2}\text{s}^{-1}$

No oscillation hy. disfavoured at  $5\sigma$

$\phi_{\text{pp}} = 6.06^{+0.02}_{-0.06} \times 10^{10} \text{ cm}^{-2}\text{s}^{-1}$  indirect meas.

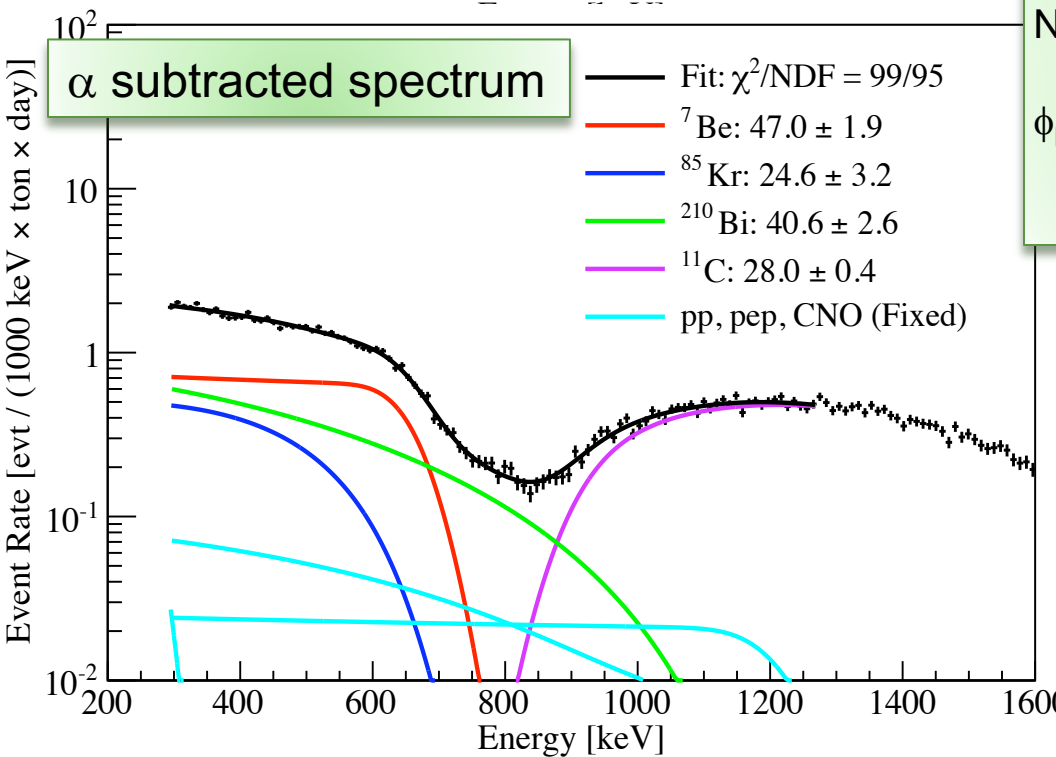

TABLE II.  $^7\text{Be}$  systematic uncertainties [%].

Source	[%]
Trigger efficiency and stability	<0.1
Live time	0.04
Scintillator density	0.05
Sacrifice of cuts	0.1
Fiducial volume	+0.5 -1.3
Fit methods	2.0
Energy response	2.7
Total systematic error	+3.4 -3.6

# pep neutrino measurement

- Predicted rate: 2.8 cpd/100tons
- Visible energy range of interest: 0.8 – 1.2 MeV
- Main background: cosmogenic  $^{11}\text{C}$   $e^+$  emitter  $T_{1/2}(^{11}\text{C}) = 20.3$  minutes
  - ~ 28 cpd/100tons
- $^{11}\text{C}$  produced by cosmogenics:  $\mu + ^{12}\text{C} \rightarrow \mu + ^{11}\text{C} + n$
- Strategy: apply the so-called Three-Fold-Coincidence (TFC) and a pulse shape discrimination between  $e^+$  and  $e^-$

# Three-Fold-Coincidence

Muon track

Spherical cut  
around neutron  
Capture to reject  $^{11}\text{C}$  event

Muons crossing the LS  
produce at least one neutron  
in 95% of cases

**Goal:** reduce  $^{11}\text{C}$  background

Neutron  
production

Cylindrical cut  
Around muon-track

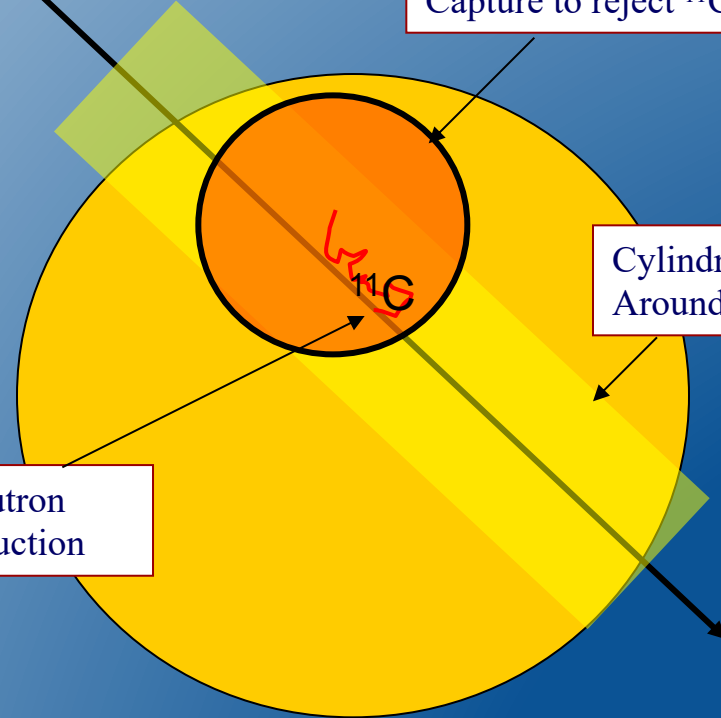

*Borexino coll: CNO and pep neutrino spectroscopy in Borexino: measurement of the deep-underground production of cosmogenic  $^{11}\text{C}$  in an organic liquid scintillator, Phys. Rev. C 74, 045805 (2006).*

TFC decreases  $^{11}\text{C}$  rate to  $\sim 10\%$  of its original value with  $\sim 50\%$  loss of exposure.

Limiting background internal  $^{210}\text{Bi}$ .

### Energy spectrum in FV

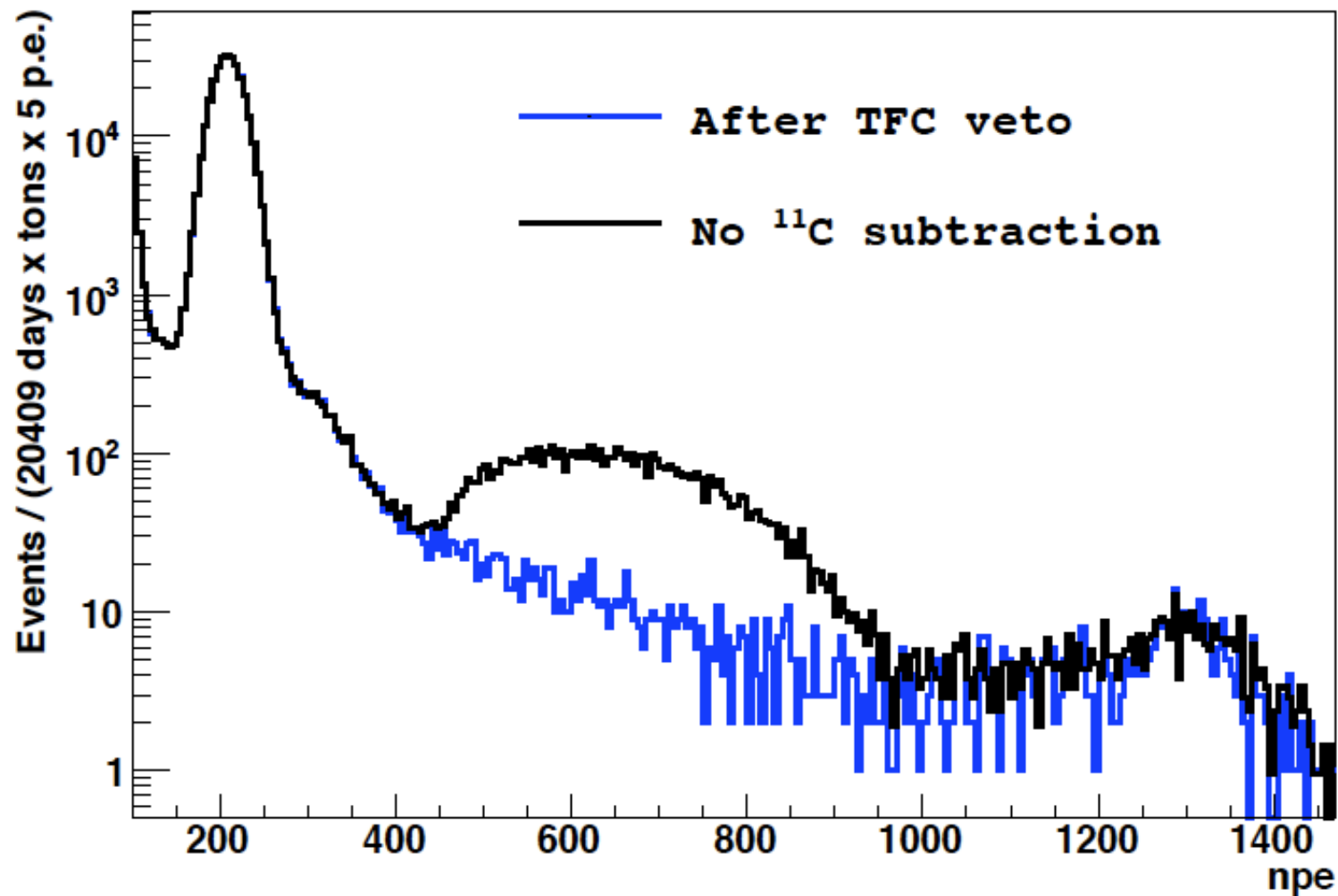

Fit of  $^{11}\text{C}$  subtracted spectrum

CNO spectrum is at 95% CL upper bound

$^{210}\text{Bi}$  main background strongly correlated with CNO

Residual spectrum after subtracting all contributions at the best-fit rates

$$R_{\text{pep}} = 3.1 \pm 0.6_{\text{stat}} \pm 0.3_{\text{sys}} \text{ cpd}/100\text{t}$$

$$\Phi_{\text{pep}} = (1.6 \pm 0.3) \times 10^8 \text{ cm}^{-2}\text{s}^{-1}$$

$$\Phi_{\text{CNO}} < 7.7 \times 10^8 \text{ cm}^{-2}\text{s}^{-1} \text{ 95\% C.L.}$$

$$\Phi_{\text{CNO}}^{\text{BX}} / \Phi_{\text{CNO}}^{\text{SSM}} < 1.5$$

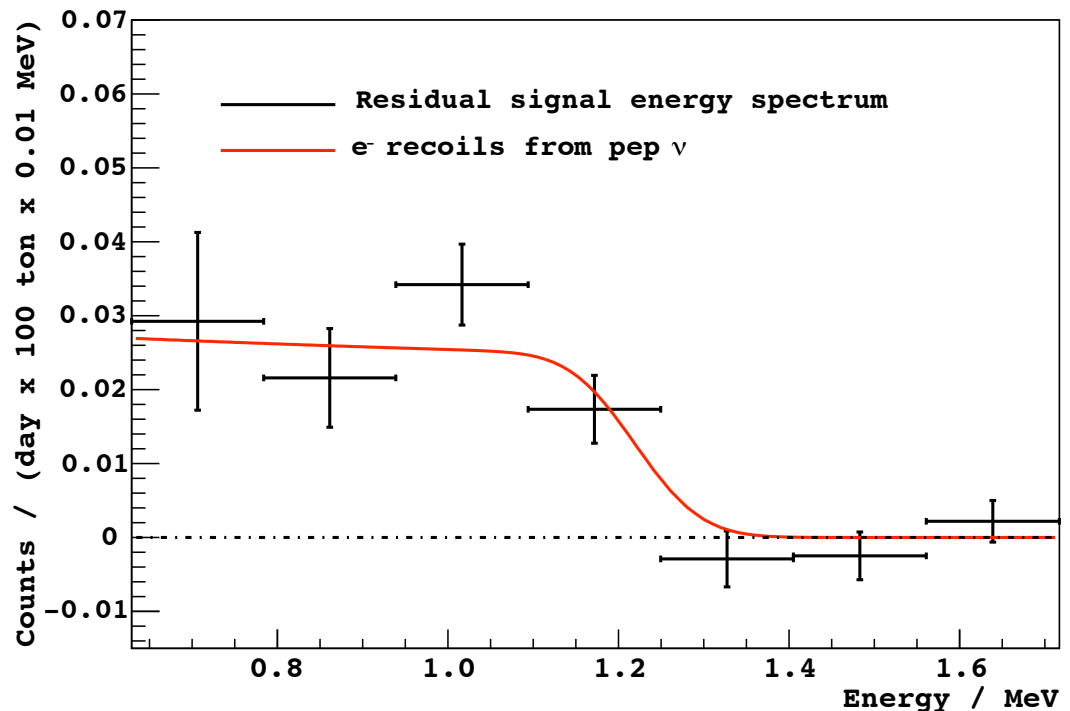
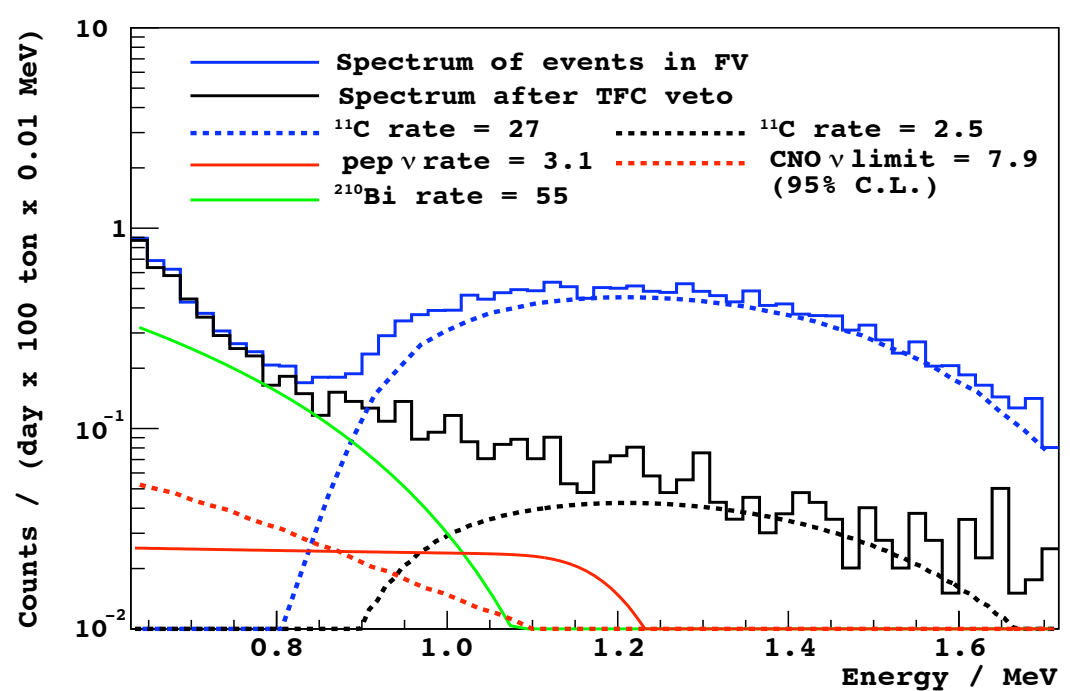

# $^8\text{B}$ solar neutrino measurement

- PRD 82 (2010) 033006
- Exposure: 345 days in 100 tons FV: Jul 2007 – Aug 2009
- $\phi_{\text{B}}^{\text{ES}} = (2.4 \pm 0.4_{\text{stat}} \pm 0.1_{\text{sys}}) \times 10^6 \text{ cm}^{-2}\text{s}^{-1}$
- no oscillation hy. excluded at  $4.2\sigma$

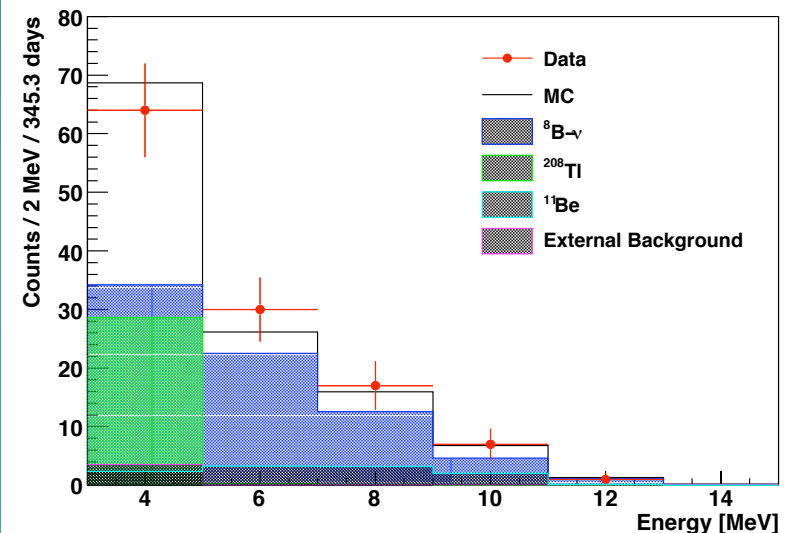
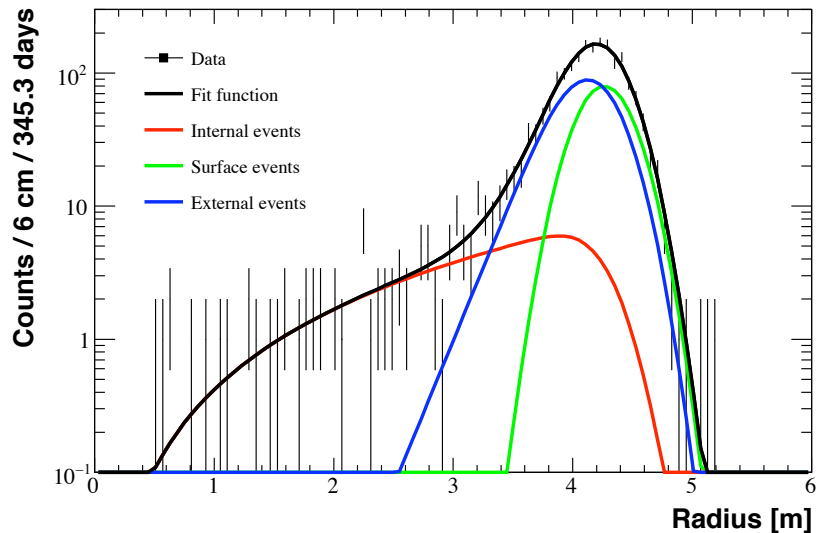

# $^8\text{B}$ solar neutrino measurements

$\nu$ -e Elastic Scattering

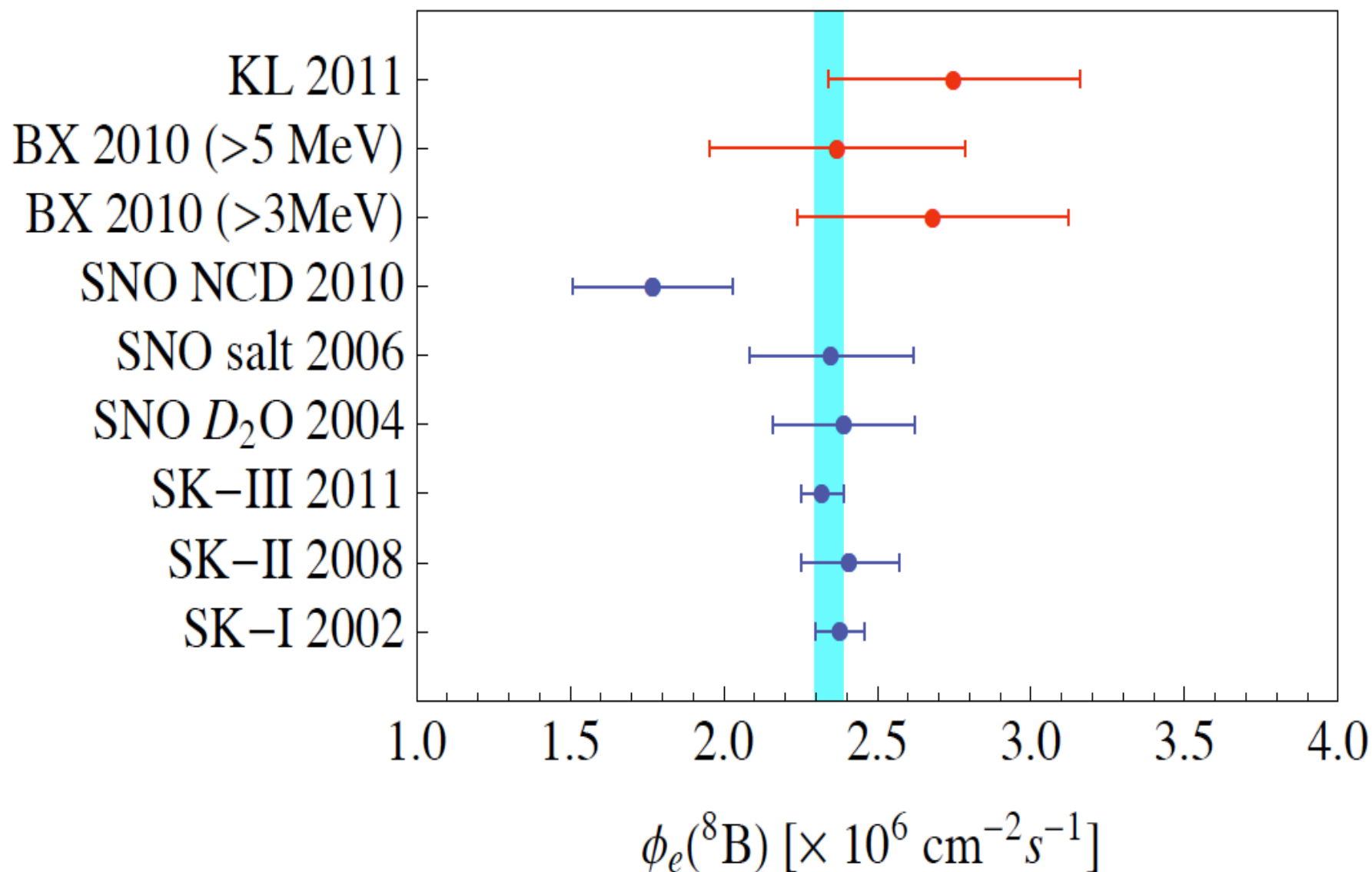

# $^7\text{Be}$ day-night asymmetry measurement

- Paper on Phys. Lett. B
- $A_{\text{dn}} = 2(R_n - R_d) / (R_n + R_d) = 0.001 \pm 0.012(\text{stat}) \pm 0.007(\text{syst})$
- $A_{\text{dn}}$  measured by fitting the day and night spectra
- exposure:
  - 360.25 days livetime
  - 380.63 night livetime

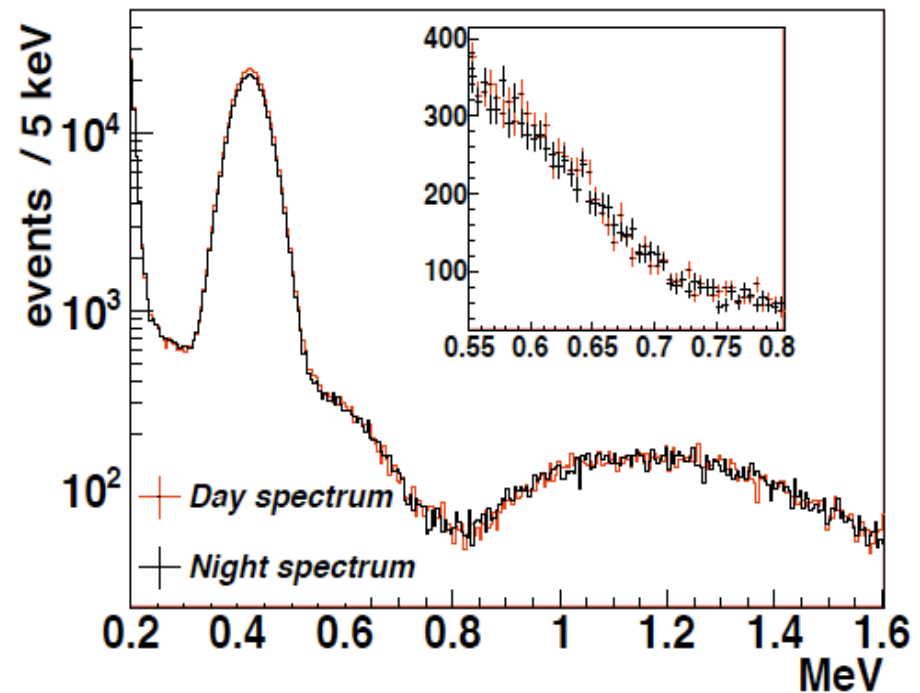

# Sensitivity

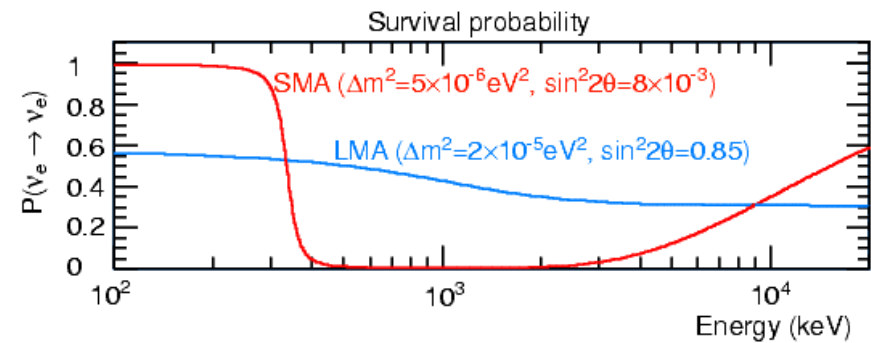
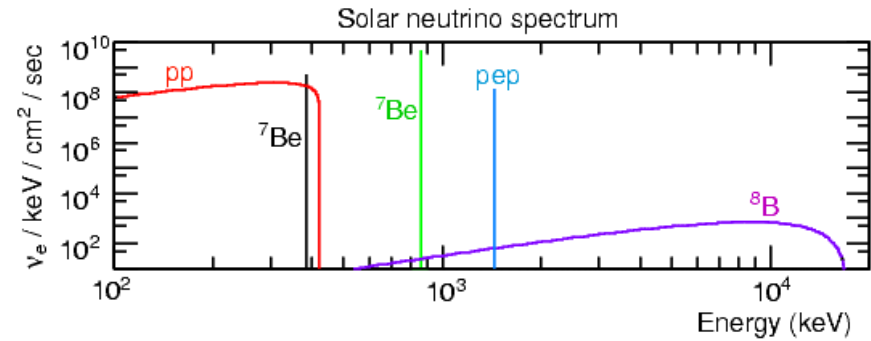
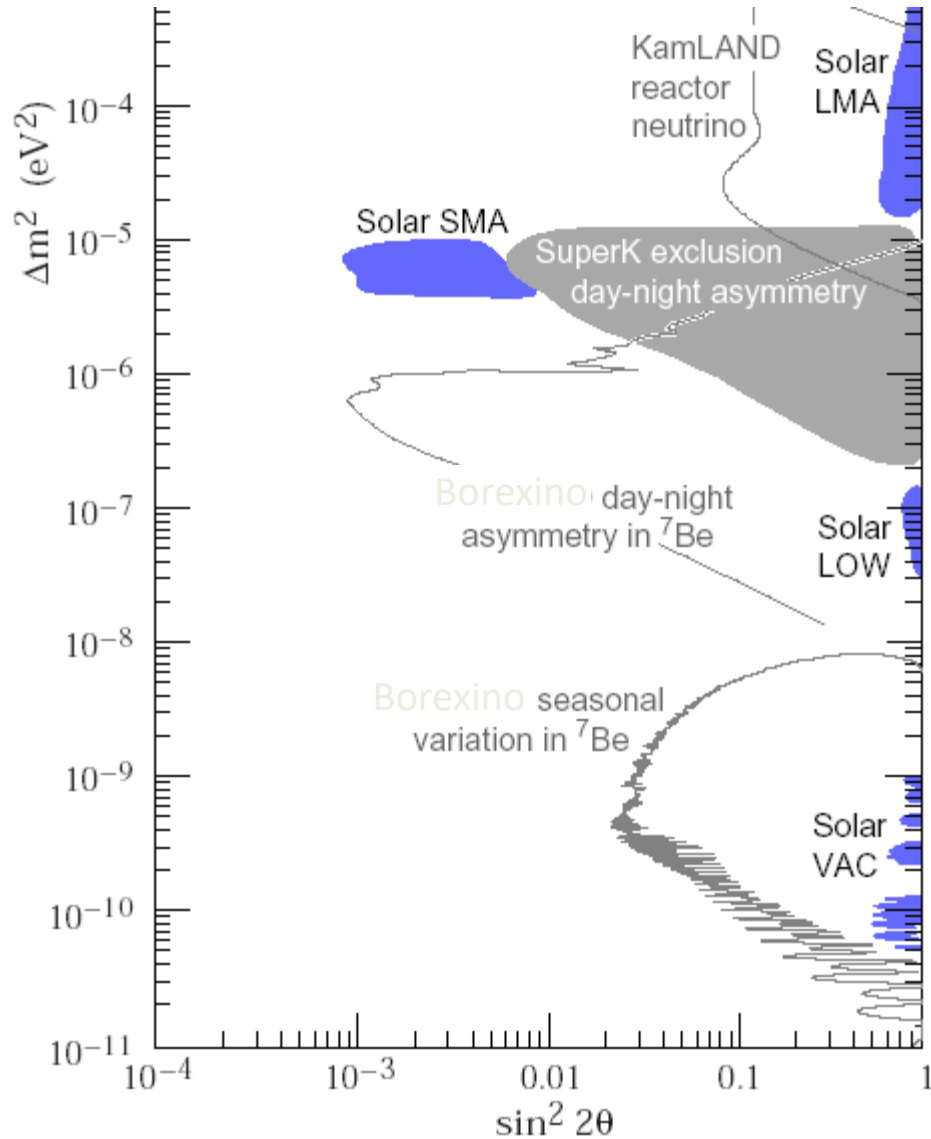

# Solar Neutrinos survival probability after Borexino

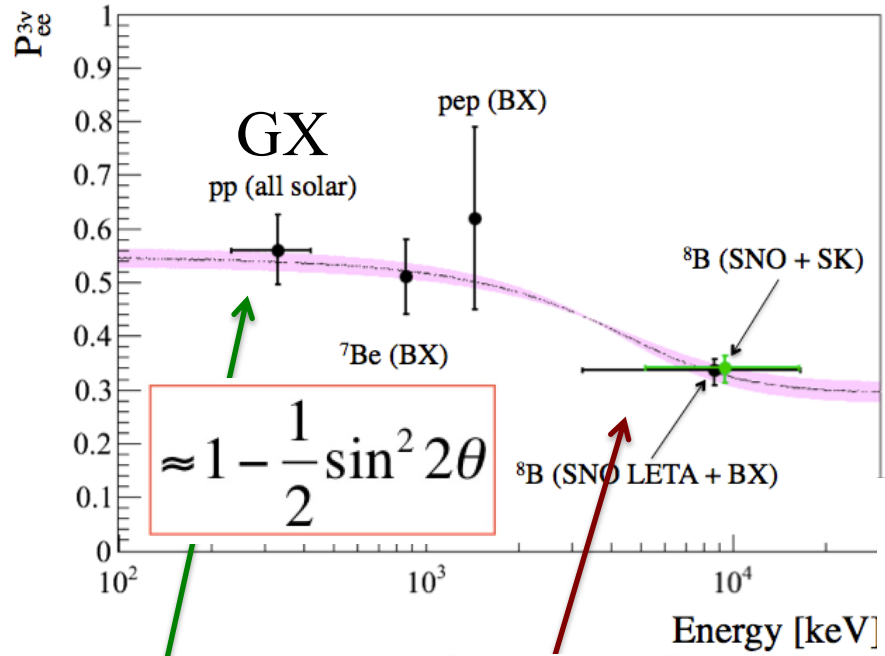

vacuum osc.

matter effect osc.

**MSW effect**  
 $\nu$  oscillation parameters' space:  
 $\Delta m^2$  vs  $\tan\theta$

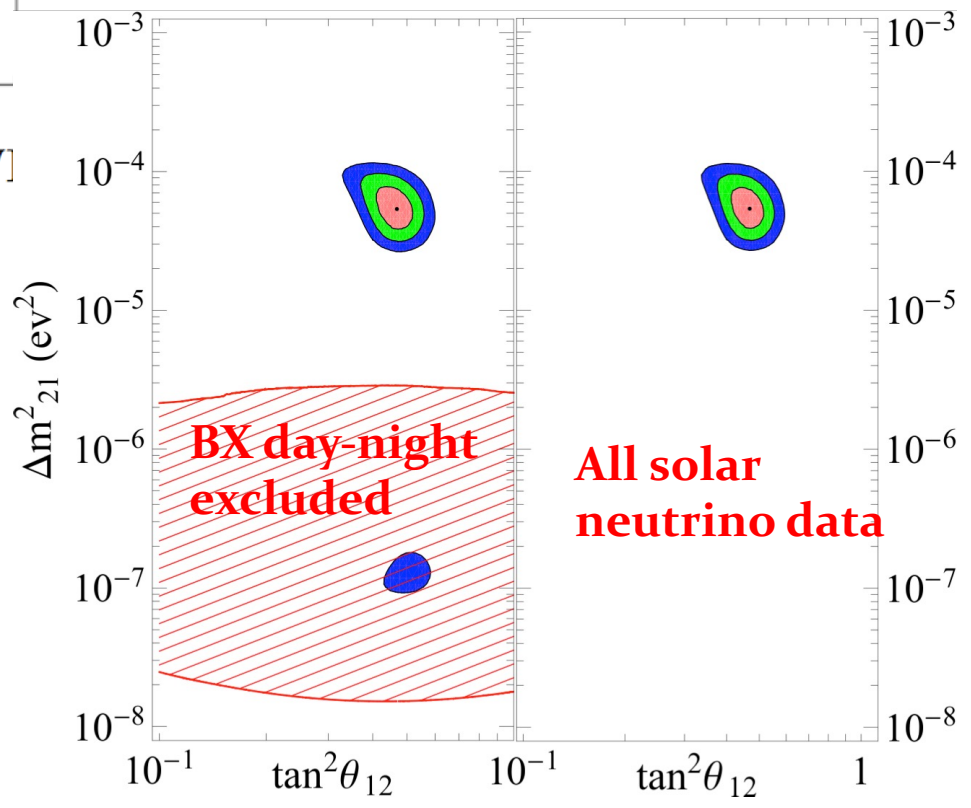

# The results of the standard spectral fit

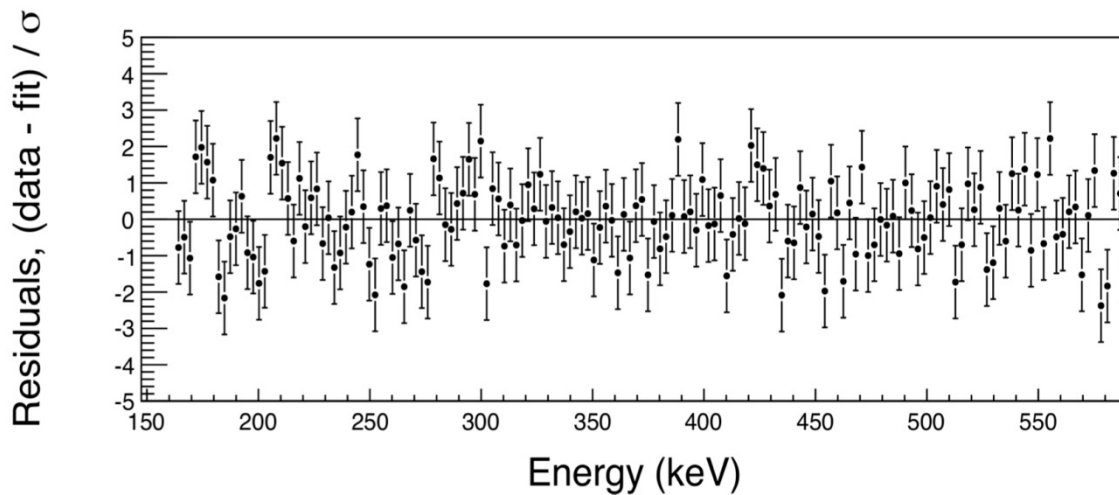
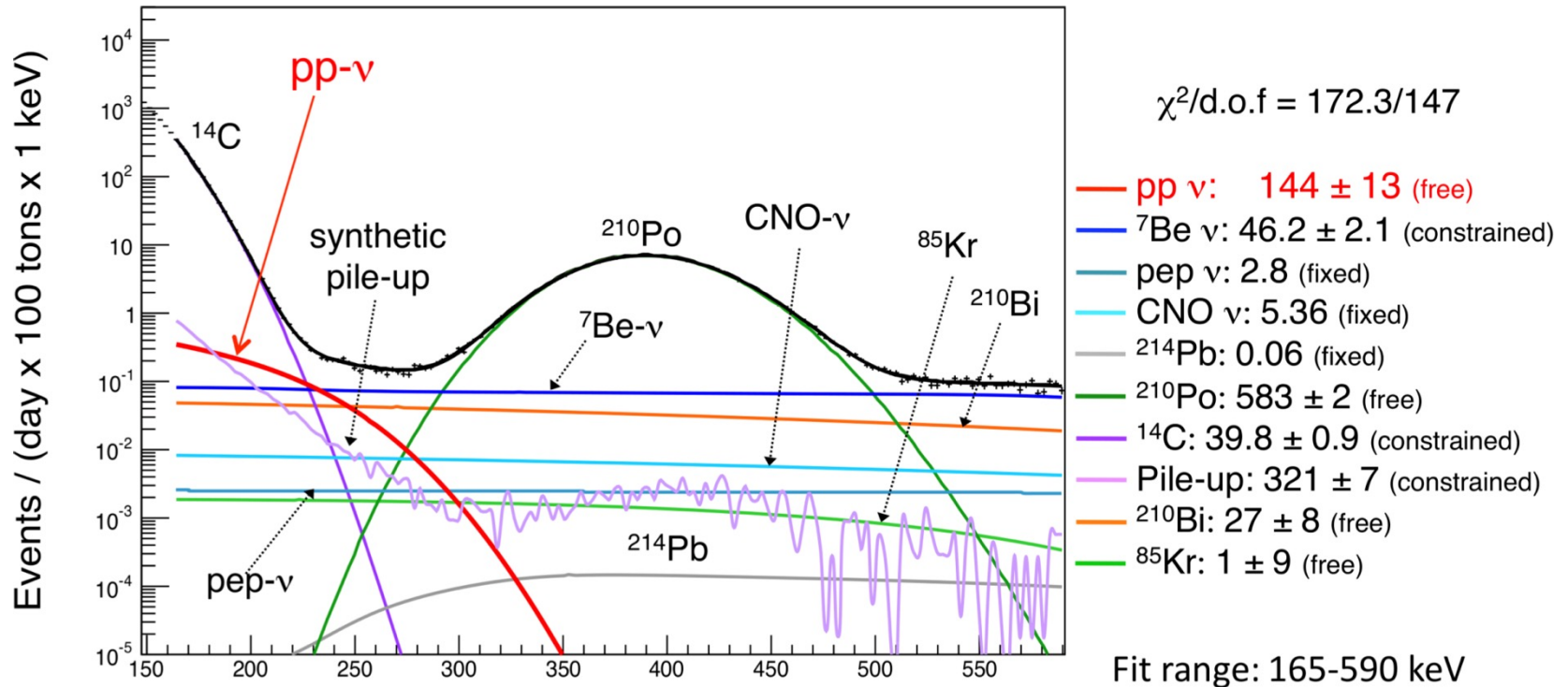

Results of 2014

# Conclusions

- **I generation of experiments has:**
  - ❑ shown the reliability of the experimental techniques
  - ❑ confirmed the basis of the stellar theories
  - ❑ pointed out the solar  $\nu$  problem
  - ❑ pointed out the solution of the  $\nu$  oscillation through the MSW effect
- **II generation of experiments has:**
  - ❑ larger target masses and more
  - ❑ more sophisticated techniques where the background due to intrinsic radioactivity of the materials becomes more important
  - ❑ confirmed the  $\nu$  oscillation
  - ❑ determined with better precision the parameters of the  $\nu$  oscillation

Further verification of the LMA solution by  
terrestrial neutrinos

Assuming CPT

**KAMLAND:** the anti- $\nu_e$  emitted by nuclear  
reactors show a deficit as that observed in the  
solar neutrinos

# Terrestrial “Solar Neutrinos”

Can we convincingly verify oscillation with man-made neutrinos?

$$P_{surv} = 1 - \sin^2 2\theta \sin^2 \left( 1.27 \frac{\Delta m^2 c^4}{\text{eV}^2} \frac{\text{GeV}}{E_\nu} \frac{L}{\text{km}} \right)$$

- Hard for low  $\Delta m^2$
- To probe LMA, need  $L \sim 100\text{km}$ , 1kt
- Need low  $E_\nu$ , high  $\Phi_\nu$
- Use neutrinos from nuclear reactors

$$\Delta m^2 = 10^{-5} \text{ eV}^2$$

$$E_\nu = 3 \text{ MeV}$$

$$L = 180 \text{ km}$$

$$\rightarrow 1.27 \Delta m^2 L / E_\nu = 0.8$$

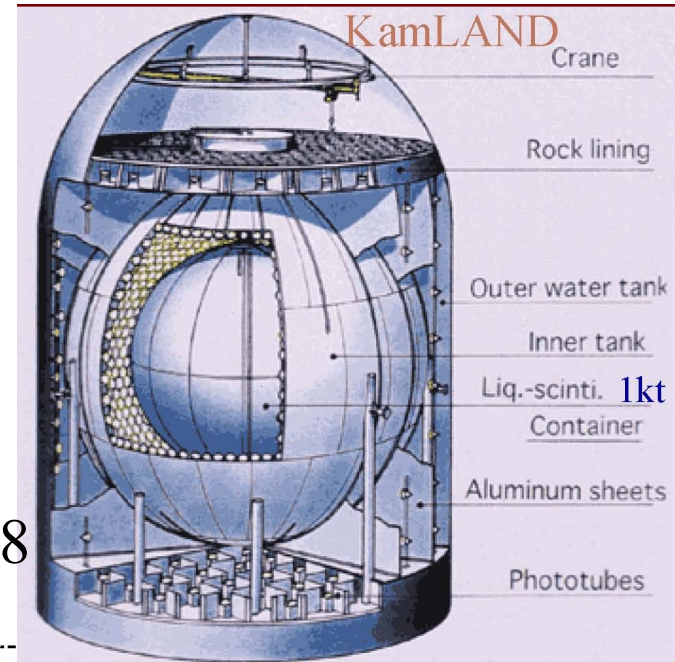

**KAMLAND: reactor anti-neutrino do oscillate!**

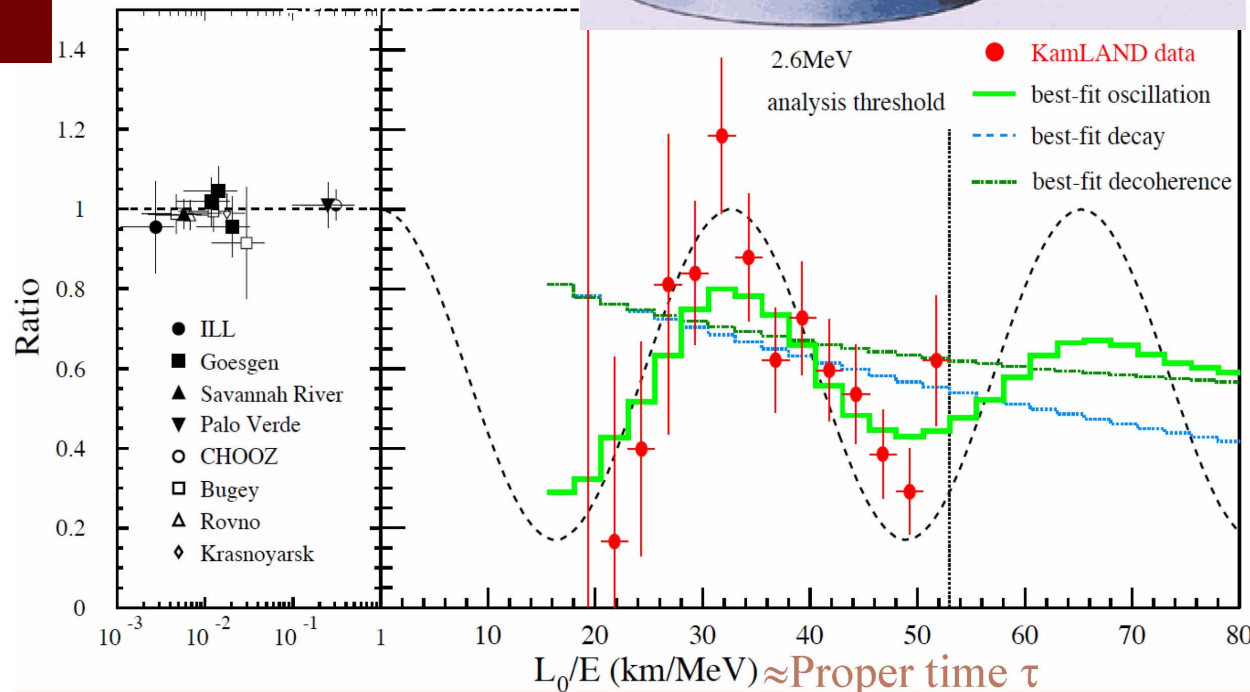

# KamLAND Long-Baseline Reactor-Neutrino Experiment



- Japanese Nuclear Reactors  
80 GW (20% world capacity)
- Average distance 180 km
- Flux  $6 \times 10^5 \text{ cm}^{-2} \text{ s}^{-1}$
- Without oscillations  
2 captures per day

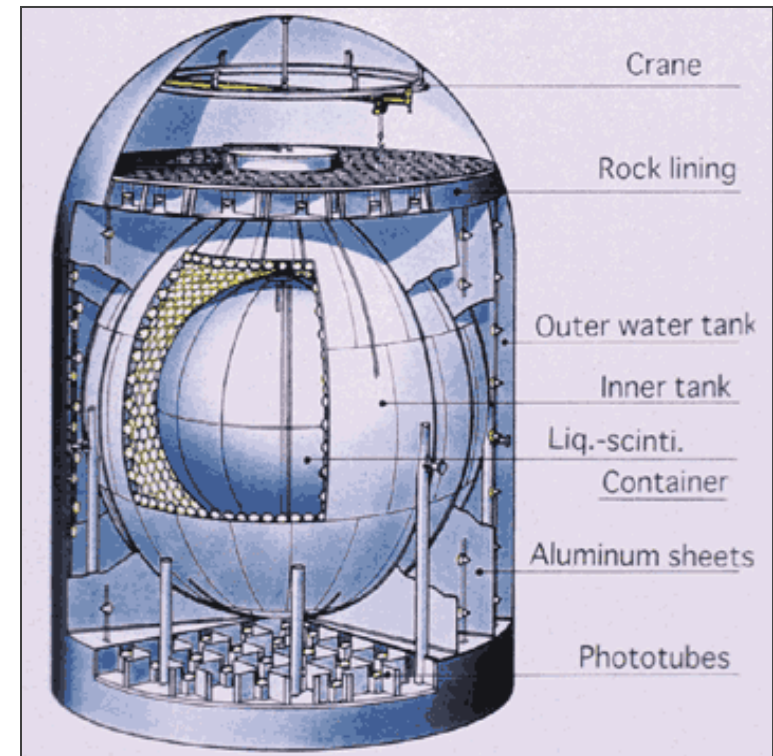

# Oscillation of Reactor Neutrinos at KamLAND (Japan)

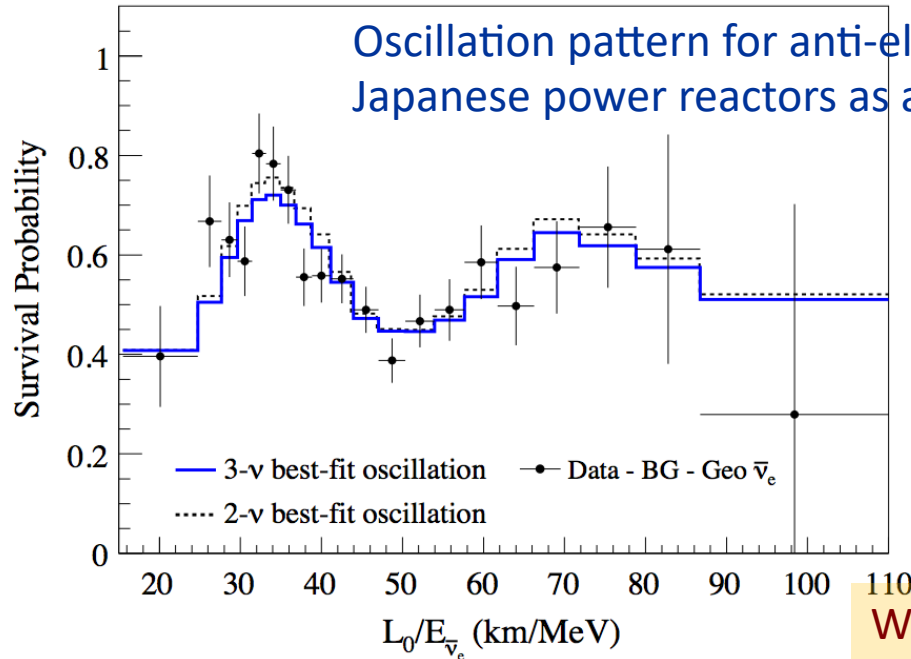

With increased statistics, KamLAND observed:

- the **distortion** of the  $\bar{\nu}_e$  spectrum
- for the first time the **periodic feature** of the  $\bar{\nu}_e$  **survival probability** expected from  $\nu$  osc

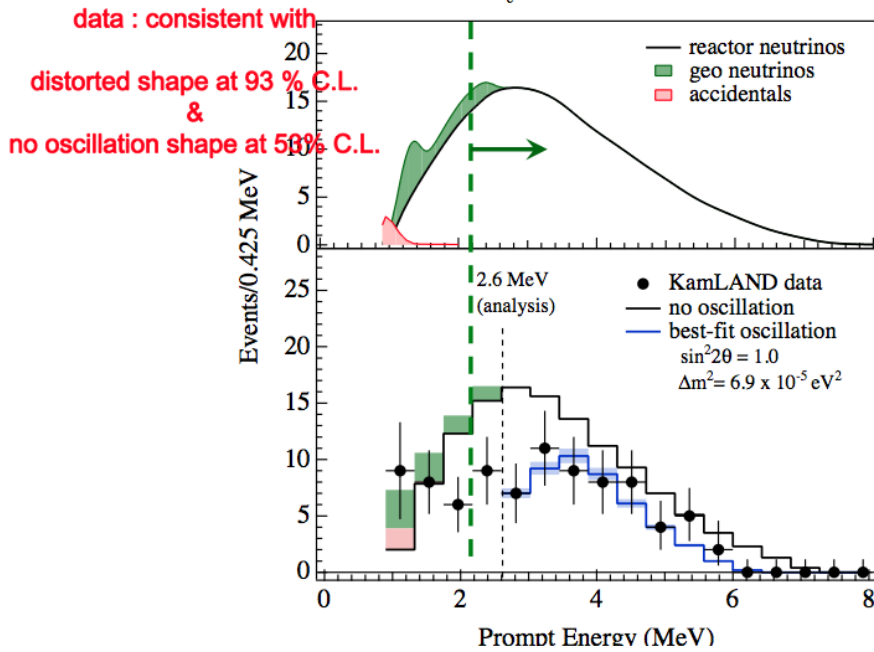

## KamLAND Scintillator detector (1000 t)

Exposure: 766 ton yr  
 Observed events: 258  
 No osc expected:  $365 \pm 24$   
 Background:  $7.5 \pm 1.3$

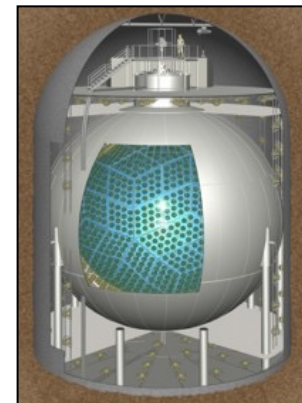

# Best-fit “solar” oscillation parameters

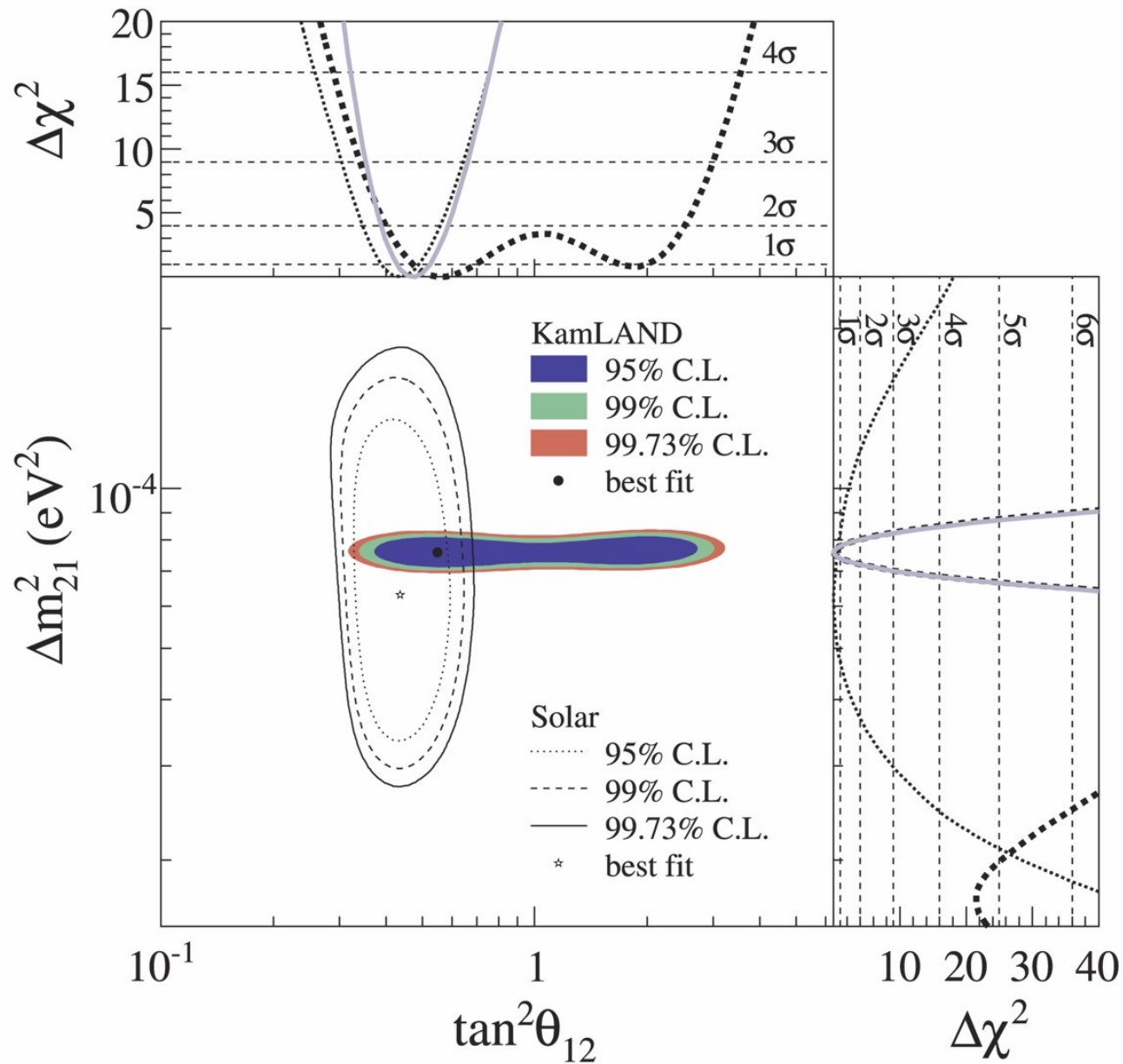

# Summary of what we learn from Solar + Reactor neutrino observations

- ✓ p-p chain supplies the bulk of solar energy
- ✓ Standard Solar Models in good shape: give the right and correct neutrino flux and are consistent with helioseismology (to few percent)
- ✓ roughly  $\nu_e = \left( \sqrt{2}\nu_1 + \nu_2 \right) / \sqrt{3}$
- ✓ Mass difference squared:  $\Delta m_{12}^2 = 7.5 \times 10^{-5} eV^2$  for  $m_2 > m_1$
- ✓ Matter effects very important (Wolfenstein, Mikheyev, Smirnov) in interpreting the solar neutrino results. Interaction of neutrinos with matter modifies their passage and the oscillations.

